



Volvo Construction Equipment

# MT2000

VOLVO HALF-LANE MILLING MACHINE



# Innovation and productivity from your trusted partner in road equipment

As a world leader in paving and compaction equipment, Volvo is proud to introduce the MT2000 milling machine, designed to meet your need for productivity, safety, and serviceability. Guided by input from customers like you, our global engineering resources have packed the MT2000 with a number of innovative features that make it one of the most advanced machines in its class. Backed by our worldwide distribution network, the MT2000 is another example of why you can trust Volvo in all phases of roadway construction and rehabilitation.

## Three distinct cutting speeds

Three available engine speeds, selectable from the control panel, allow you to match cutting productivity, fuel consumption, and sound level to individual job requirements. The "Deep-cut Power Bulge" low-speed selection is available for tough or deep-cut efficiency while the high-speed selection offers the highest productivity on shallow cuts. The standard cutting speed provides maximum horsepower and efficiency at normal cutting depths.

## Advanced diagnostics and communication

The MT2000 incorporates advanced technology for machine diagnostics and troubleshooting. Choose from multiple diagnostic screens for detailed information on machine performance. Messages are displayed in common language, rather than codes, to aid in understanding.

## Load control technology

Improve overall productivity with load control technology from Volvo. This feature balances engine load with travel speed to ensure efficiency and maximize productivity.

## Stability control system

A dedicated sensor monitors the cross slope of the machine and adjusts the support legs until the machine is within the acceptable balanced range.

## Walk-in service compartment

The innovative walk-in service compartment allows easy access to the engine, hydraulic components, batteries, fan and coolers. This gives you the benefit of working in a protected environment, while the shorter diagnostic and maintenance intervals will add value to your bottom line.

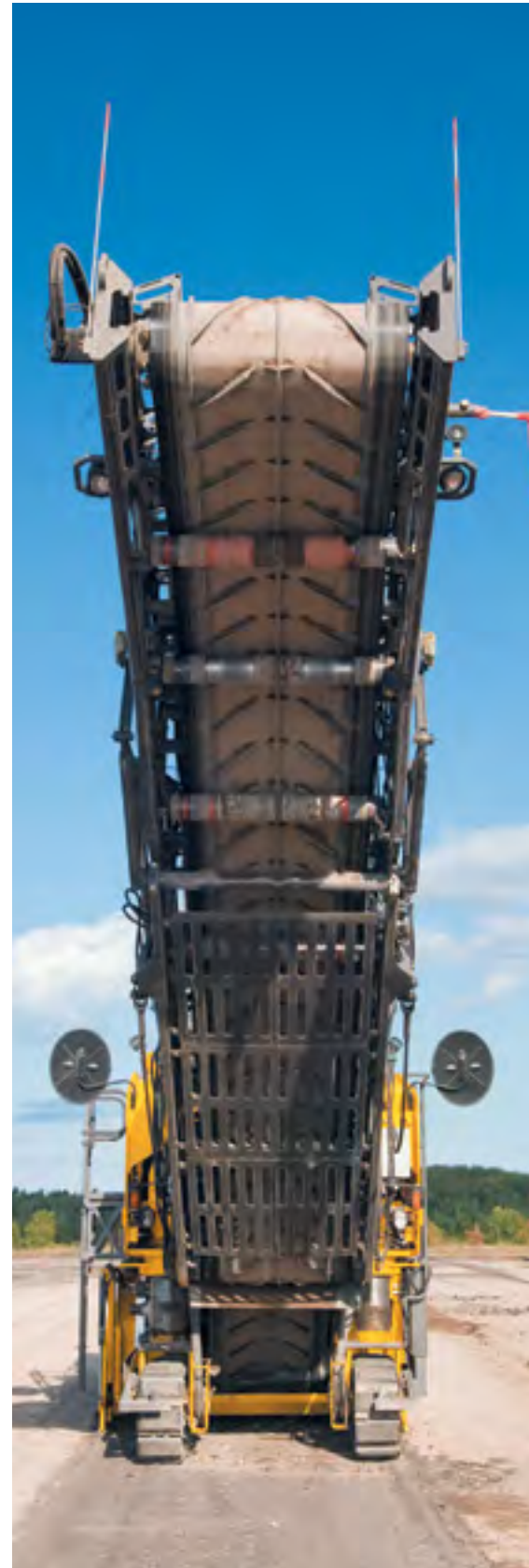



# Designed for your productivity and safety

## Microprocessor-controlled engine

- Tier 3-compliant, Cummins diesel engine
- 454,88 kW (610 hp) at 1 900 rpm

## Operator comfort

- Identical operator consoles with four-way sliding seats
- Seat and console can extend laterally beyond the machine frame for improved visibility
- Adjustable control consoles and vibration-isolating deck mat for operator comfort
- Folding right-side platform and stairway folds flush for transport and provides access from both sides of the machine

## Versatile ground controls

- Ground control stations located at each corner of the machine
- For increased flexibility, ground-level steering controls located on both sides of the machine - near the center of the tracks - provide the ground crew with the same precise steering available on the operator's station
- Grade control panel(s) can be located in any of six ground locations or in main operator area for optimum versatility
- Optional sonic grade control sensors can be mounted in any of six ground locations to meet jobsite referencing requirements

## Support legs and tracks

- Four-track configuration features robust support legs with over-center valves, greater control, smoother operation
- Tapered roller bearings in track rollers reduce track overheating for longer life

## High-production conveyors

- 91,44 cm (36 in) gathering and discharge conveyors have theoretical capacity of 1 003,49 cubic meters (35,438 cubic feet) per hour
- Independent controls
- Variable speed
- Reversible direction
- Automatic hydraulically tensioned belts
- Conveyor cover and under-side material guards
- Hydraulically raised gathering conveyor
- Optional hydraulically folding discharge conveyor

## Robust cutter box

- Drum is available in 2 000 mm (79 in) and 2 185 cm (86 in) widths
  - Quick-change or weld-on holders
  - Fine or standard spacing patterns



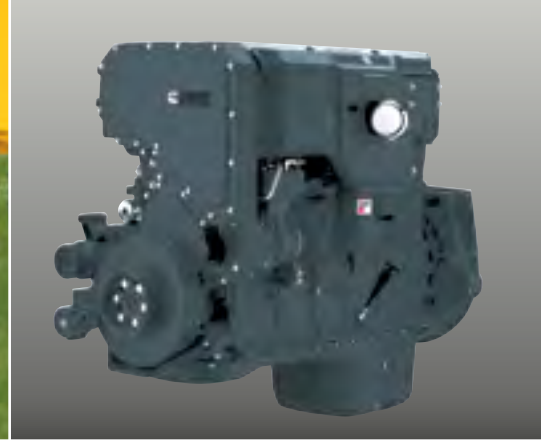

**Serviceability**

- Walk-in service compartment with easy access to engine, hydraulic components, fan and coolers
- Gathering conveyor can be removed for service without removing discharge conveyor
- Microprocessor provides error related checking
- Open access to all four batteries for easy service and removal

**Variable water spray system**

- Easily accessible spray bars in each conveyor for dust suppression
- Spray bars in drum area for cutter teeth cleaning and cooling
- All spray bars independently adjustable
- Automatic water pump shut-off when tank empties or when line gets clogged



**Over-center valves**

- Located on support legs, conveyor lift, and swing cylinders
- Provide greater operator control over these functions

**Anti-spin control**

- Promotes continuous tractive effort and increased productivity

**Safety devices**

- Seven emergency stop buttons
- Seven strobe lights
- Multiple audible alarms
- Object detection sensors

**Stability control system**

- Dedicated sensor monitors machine cross slope and adjusts support legs until machine is within the acceptable balanced range

**Adjustable work lights**

- Twelve fixed base halogen work lights
- Six magnetic base halogen work lights
- Both for optimal nighttime visibility

# Operation and diagnostics at your fingertips

The MT2000 incorporates advanced technology for machine diagnostics with intuitive operator panels that are easy to understand and operate. Each control panel includes a brightly illuminated display panel that allows the operator to view the master control screen or one of the various diagnostic screens.

- An intuitive switch layout and easy-to-understand international labels promote safety and ease of operation
- The primary function screen displays a summary of basic machine performance and operation settings. The machine overview conveniently displays real-time track positioning
- The One Touch system makes maneuvering a breeze. Pressing the switch once raises the two front legs of the machine and turns off conveyors, water, and pauses the grade controls when you need to rise over manhole covers and other application obstacles. When you're ready to transport out of the cut, pressing the switch twice within three seconds raises all four legs of the machine and turns off conveyors, water, grade controls, and the drum.
- Additional diagnostic screens provide detailed information on:
  - Engine and hydraulic performance
  - Propel, drum, and conveyor information
  - Automation and lighting
- Performance messages and diagnostic information are displayed in local language, rather than codes, to aid in troubleshooting
- LED indicators show power to the valve for ease of switch troubleshooting
- Backlit membrane switches provide excellent fiber-optic illumination for nighttime milling applications

## A machine designed with you in mind

In addition to putting all our global engineering resources into this milling machine, we sought out customer input to better understand the challenges you face on a daily basis. We know you're out there every day, and we know how productivity and reliability determine the success of your business.

This new milling machine allows us to serve you at all stages of the road-building process.

The Volvo road machinery business has a proud, 175-year legacy that has produced many industry standards and remains the choice of professionals. Combined with our full line of road machinery products — including motor graders, pavers, and compactors — these machines will help you achieve maximum productivity in all phases of the road construction and rehabilitation process.

The MT2000 completes the following applications with ease, from mill to fill, to full depth removal:

- Parking lots
- City streets
- County roads
- Shoulders
- Highways
- Airports



# Support you can trust

When you buy a Volvo, you get more than a construction machine of the highest quality.

You also get access to all the products and all the competence that is required for your machine to give you maximum profit and growth.

## **We care about your ownership — today and tomorrow**

When you invest in a Volvo construction machine, you get a construction machine of the very highest quality. But of course, even the best machine needs service and maintenance, especially considering the extreme stresses to which your machine is subjected. Your machine shouldn't only be productive today, but tomorrow as well.

## **We care about your operation — anywhere at any time**

When you invest in a construction machine, the knowledge of having good service and access to the right parts is just as important as the price — if not more important. After all, it is the total cost during the machine's entire life that's interesting. With all the products and resources we have at our disposal, we can offer you the very best support. Anywhere at any time.

## **We care about the operator — day after day**

An aspect of major importance in Volvo machines is the operator's environment. If it isn't good, it doesn't matter how good the rest of the machine is.

A machine operator has a job full of responsibility, and the productivity demands are high. Operators with a safe, comfortable, and ergonomic operator's station do a better job and get more out of their machine. Day after day.

## **Genuine Volvo Parts**

Genuine Volvo Parts constitute a system where each individual part is designed for perfect function with the other parts. By always using Genuine Volvo Parts, your Volvo will retain the features it had when you bought it.

## **High competence and the right tools — profitable for you**

We are specialists who know your machine, and all our service technicians have the competence and the commitment required to give you peace of mind and good economy in your operation. With the right competence we do the job faster, saving you valuable time. We also do the job in the right way and with the right tools.







# Specifications

Model		MT2000 (with 2 000 mm drum)	MT2000 (with 2 185 mm drum)
<b>Machine Weights</b>			
Shipping Weight	kg (lb)	31 797 (70,100)	32 568 (71,800)
Operating Weight*	kg (lb)	34 156 (75,300)	34 927 (77,000)
Maximum Operating Weight**	kg (lb)	36 514 (80,500)	37 285 (82,200)
<b>Machine Dimensions</b>			
Overall Length (with conveyor)	mm (in)	14 572 (574)	14 572 (574)
Overall Length (without conveyor)	mm (in)	7 140 (281)	7 140 (281)
Overall Width	mm (in)	2 500 (98)	2 685 (106)
Overall Height	mm (in)	3 000 (118)	3 000 (118)
<b>Drum Dimensions</b>			
Drum Width	mm (in)	2 000 (78.75)	2 185 (86)
Drum Diameter	mm (in)	1 219 (48)	1 219 (48)
Milling Depth	mm (in)	0 - 355 (0 - 14)	0 - 355 (0 - 14)
Milling Radius - Left	mm (in)	1 677 (66)	1 677 (66)
Milling Radius - Right	mm (in)	1 677 (66)	1 492 (58)
Tooth Spacing	mm (in)	15 (0.625)	15 (0.625)
Number of Teeth		146	158
<b>Undercarriage</b>			
Type		(4) track	(4) track
Dimensions (L x W x H)	mm (in)	1 750 x 300 x 655 (69 x 12 x 26)	1 750 x 300 x 655 (69 x 12 x 26)
Steering Modes		Front, rear, crab, coordinated	Front, rear, crab, coordinated
Theoretical Turning Radius	mm (in)	1 500 (59)	1 500 (59)
Travel Speed	m/min (mph)	0 - 91,4 (0 - 3.4)	0 - 91,4 (0 - 3.4)
Working Speed	m/min (fpm)	0 - 57,3 (0 - 188)	0 - 57,3 (0 - 188)
<b>Engine</b>			
Make / Model		Cummins QSX-15	Cummins QSX-15
Cylinders		6	6
Cooling		Liquid-cooled	Liquid-cooled
Engine Speeds Available	rpm	1 500, 1 900, 2 300	1 500, 1 900, 2 300
Max Power @ 1 900 rpm	kW (hp)	455 (610)	455 (610)
Max Torque @ 1 400 rpm	Nm (ft-lb)	2 550 (1,875)	2 550 (1,875)
<b>Conveyors</b>			
Gathering Conveyor Width	mm (in)	915 (36)	915 (36)
Discharge Conveyor Width	mm (in)	915 (36)	915 (36)
Discharge Conveyor Swing Angle		+ / - 55°	+ / - 55°
Discharge Conveyor Theoretical Capacity	m <sup>3</sup> /hr (yd <sup>3</sup> /hr)	1 003,49 (1,312.5)	1 003,49 (1,312.5)
<b>Miscellaneous</b>			
Fuel Capacity	l (gal)	1 440 (380)	1 440 (380)
Hydraulic Tank Capacity	l (gal)	303 (80)	303 (80)
Water Capacity	l (gal)	3 486 (920)	3 486 (920)
Electrical System		24 volt	24 volt
Operator Ear	dBA	88	88
Machine Sound Power	dBA	115	115

\* Weight with 1/2 water, 1/2 fuel, and 80 kg (175 lb) operator \*\* Weight with full water, full fuel, and 80 kg (175 lb) operator \*\*\* Distance to edge of sideskirt

# Machine Dimensions

Dimension	mm (in)
A	300 (11.8)
B	700 (27.6)
C	1 350 (53.1)
D	450 (17.7)
E	300 (11.8)
F	300 (11.8)
G	375 (14.8)
H	1 500 (59.0)
I	625 (24.6)
J	300 (11.8)

Dimension	mm (in)
K	4 750 (187.0)
L	4 210 (165.7)
M	7 432 (292.6)
N	7 140 (281.1)
O	14 572 (573.7)
P	1 075 (42.3)
Q	2 600 (102.4)
R	2 200 (86.6)
S	1 220 (48.0)
T	1 219 (48.0)
U	3 000 (118.1)

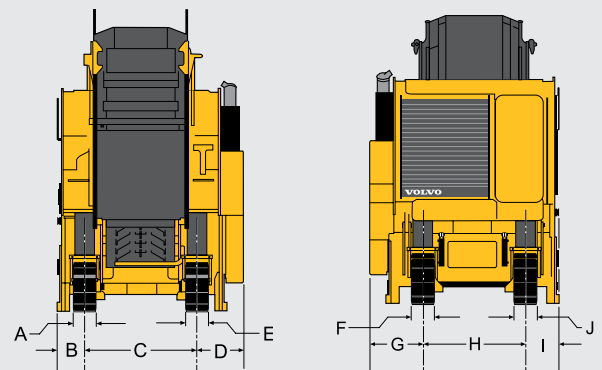

## FEATURES

Operator Areas	Std	Opt
Dual Operator Consoles with Adjustable Seats	•	
Dual Console Storage	•	
Vibration-isolating Operator Area Deck Mat	•	
Dual Control Panels with LCD Display	•	
Machine Performance Summary Screen	•	
Machine Diagnostics with Multiple Screens	•	
(8) Language Communication Capability	•	
(3) External Mirrors	•	
(12) Fixed work lights and 6 Magnetic Work Lights	•	
(7) Emergency Stop Buttons	•	
(7) Strobe Warning Lights	•	
Back-up Alarm	•	
(4) Ground Control Panels	•	
Radar Sensor	•	

Grade Slope and Controls	Std	Opt
Prepared for Levelling System	•	
Prepared for Sonic Averaging***	•	
MOBA Slope Control Sensor	•	
(1) MOBA MMI Grade and Slope Control Panel	•	
Choice of (2) MOBA Wire-rope or (2) MOBA Sonic Grade Sensors	•	
Additional MOBA MMI Grade and Slope Control Panel(s)		•
Additional MOBA Sonic Grade Control Sensor(s)		•

\*\*\* May require additional sonic grade control sensor(s) for sonic averaging

Drum Housing	Std	Opt
Hydraulically-raised Drum Side Skirts	•	
Hydraulically-raised Rear Moldboard	•	
Drum Moldboard Lock Valve	•	
Drum Housing Water Spray Bar	•	

Warranty	Std	Opt
1 Year / 1 500 Hours	•	

Undercarriage	Std	Opt
(4) Heavy-duty Track Support Legs	•	
Front, Rear, Crab, and Coordinated Steer Modes	•	
Anti-spin Control	•	
Stability Control	•	
Choice of Rubber or Polyurethane Track Pads	•	

Conveyors	Std	Opt
Non-folding Discharge Conveyor	•	
Hydraulically Folding Discharge Conveyor		•
Hydraulically Tensioned Conveyors	•	
Adjustable Speed Conveyors	•	
Reversible Direction Conveyors	•	
Independently Controlled Conveyors	•	
Hydraulically Raised Gathering Conveyor	•	
Anti-slabbing Gathering Conveyor Support	•	
Water Spray Bar in Each Conveyor	•	

Drums	Std	Opt
2 000 mm (78.75 in) Drum Width	•	
2 185 mm (86 in) Drum Width		•
KPF301 Quick-change Tooth Holders	•	
C10LG Weld-on Tooth Holders		•
15 mm (.625 in) Tooth Spacing	•	
8 mm (.3125 in) Tooth Spacing, 5 mm (.1875 in) Tooth Spacing		•

Service	Std	Opt
Walk-in Service Compartment	•	
Real time Performance / Service Messaging	•	
Reversible Fan	•	
Cyclonic Air Filter	•	

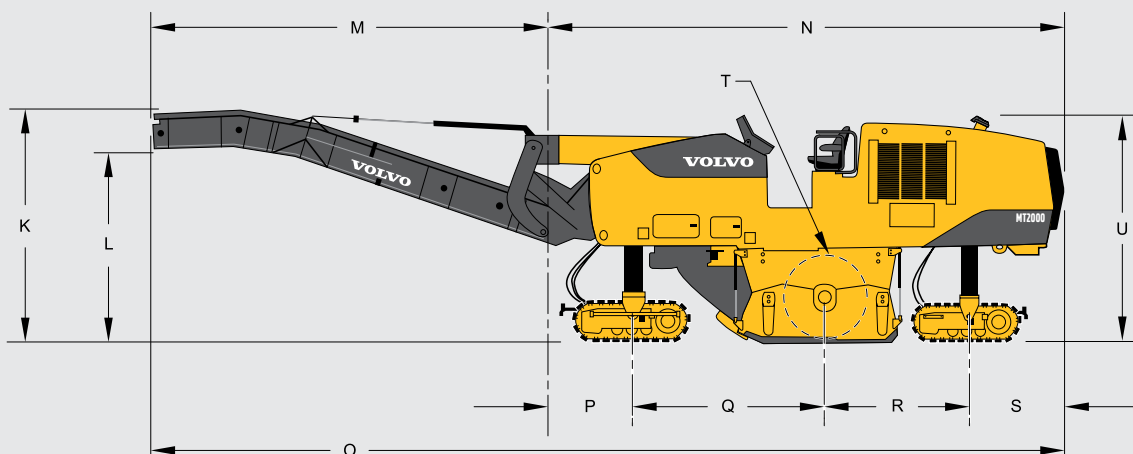



**VOLVO**

Volvo Construction Equipment

[www.volvoce.com](http://www.volvoce.com)