

V O L V O



Volvo Wheel Loaders 14.0 t / 30,880 lb 170 hp

L70H

Volvo Construction Equipment

L70H

Leave the heavy-duty work for the L70H, designed to do more, be more comfortable and help you increase your productivity.



Designed to do more

Hard work has never felt so easy. H-Series wheel loaders are built with an industry-leading, strong frame, which, combined with the ideally-matched genuine Volvo drivetrain, achieves long-lasting performance. And with the help of a range of smart apps you can boost the efficiency of your operation from the comfort of the cab.



Loaded with versatility

- Torque Parallel linkage
- Volvo attachment bracket
- Range of purpose-built attachments
- Rehandling bucket
- 3rd and 4th hydraulic functions



Keep it moving

- Quick hydraulic oil fill thanks to new mounted nipple
- Improved cooling capacity
- Strong frame and central hinge
- Standard delayed engine shutdown
- Optional external axle cooling
- Optional Load Assist Tire Pressure monitoring



Safety as standard

- Anti-slip steps and strategically placed handrails
- Orange three-point seatbelt
- Redesigned side mirrors
- Rear-view camera



Strong and stable

- Optimized loading unit weight, heavyduty counterweight for greater stability
- Standard electro-servo controls
- Auto Bucket leveling function
- Lifetime Frame warranty



Increased productivity

- Optional lock-up converter
- Rimpull control
- Smart Control
- Smooth Control
- Eco pedal
- Load Assist On-Board Weighing hardware- Standard
- Load Assist Operator Coaching - Standard



Greater access

- Cooler installation slides out for easier cleaning
- Repositioned fill spouts for transmission and engine oil
- Ground-level access to service points
- Electronically-operated engine hood

Volvo L70H in detail

Engine

6-cylinder, 6 liters inline turbocharged diesel engine with an advanced fuel injection system with the common rail. Fuel is distributed under high pressure from a high-pressure accumulator, the rail. One belt driven high pressure pump deliver the fuel to the rail and then further on via high-pressure pipes to the electronically operated fuel injectors. Engine meets Tier 4f / EU Stage V emission legislation.

Engine	Volvo	D6J
Max. power at	r/min (r/s)	1 500 - 1 800 (23.3 - 28.3)
ISO 14396 gross	kW (hp)	127 (170)
ISO 9249, SAE J1349 net	kW (hp)	127 (170)
Max. torque at	r/min (r/s)	1,400 (23.3)
ISO 14396 gross	Nm (ft lbf)	850 (627)
ISO 9249, SAE J1349 net	Nm (ft lbf)	850 (627)
Economic working range	r/min (r/s)	800 - 1 600 (13.3 - 26.8)
Displacement	l (in ³)	57 (348)

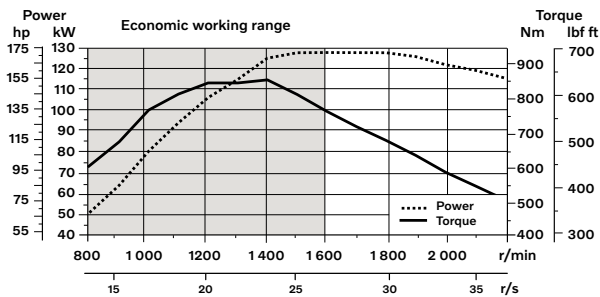

Electrical System

Contronic electrical system with central warning light and buzzer for following functions: - Serious engine fault, Low steering system pressure, Over speed warning engine, Interruption in communication (computer fault), Central warning light and buzzer with the gear engaged for the following functions: Low engine oil pressure, High engine oil temperature, High charge air temperature, Low coolant level, High coolant temperature, High crank case pressure, Low transmission oil pressure, High transmission oil temperature, Low brake pressure, Engaged parking brake, Fault on brake charging, Low hydraulic oil level, High hydraulic oil temperature, Overspeeding in engaged gear, High brake cooling oil temperature front and rear axles, etc.

Batteries	V	2 x 12
Battery capacity	Ah	2 x 110
Cold cranking capacity, approx	A	1,000
Alternator rating	W/A	3 135/80
Starter motor output	kW	55

Brake system

Service brake: Volvo dual-circuit system with outboard mounted, hydraulically operated, fully sealed and circulating oil cooled wet disc brakes. Four operator selectable transmission disengagement settings while braking.

Parking brake: Dry disc brake mounted on the transmission output shaft. Applied by spring force, electro-hydraulically released with a switch on the instrument panel.

Secondary brake: Dual brake circuits with rechargeable accumulators.

Standard: The brake system complies with the requirements of ISO 3450, 71/320/EEC

Number of brake discs per wheel		1
Accumulators	l (gal)	2 x 0.5+1 x 1.0 (2 x 0.13 + 1 x 0.26)
Accumulators for parking brake	l (gal)	1 x 1.0 (1 x 0.26)

Lift Arm System

Torque parallel linkage (TP-linkage) with high breakout torque and parallel lift-arm action.

Lift cylinders		2
Cylinder bore	mm (in)	110 (43)
Piston rod diameter	mm (in)	70 (28)
Stroke	mm (in)	756 (298)
Tilt cylinder		1
Cylinder bore	mm (in)	160 (63)
Piston rod diameter	mm (in)	90 (35)
Stroke	mm (in)	432 (17)

Steering System

System supply: The steering system has priority feed from a load-sensing axial piston pump with variable displacement.

Steering cylinders: Two double-acting cylinders.

Steering cylinders		2
Cylinder bore	mm (in)	70 (28)
Rod diameter	mm (in)	45 (18)
Stroke	mm (in)	386 (152)
Working pressure	MPa (bar)	21 (210)
Maximum flow	l/min (gal/min)	60 (159)
Maximum articulation	± °	40

Cab

Instrumentation: All important information is centrally located in the operator's field of vision. Display for Contronic monitoring system.

Heater and defroster: Heater coil with filtered fresh air and fan with auto and 11 manual speed settings. Defroster vents for all window areas.

Operator's seat: Operator's seat with adjustable air suspension and retractable seatbelt. The seat is mounted on a bracket on the rear cab wall and floor. The forces from the retractable seatbelt are absorbed by the seat rails.

Standards: The cab is tested and approved according to ROPS (ISO 3471), FOPS (ISO 3449). The cab meets with requirements according to ISO 6055 (Operator overhead protection - Industrial trucks) and SAE J386 (Operator Restraint System).

Emergency exit: Use emergency hammer to break window

Ventilation	m ³ /min (yd ³ /min)	9 (118)
Heating capacity	kW	16
Air conditioning (optional)	kW	75

Sound Level

Sound pressure level in cab according to ISO 6396		
L _{pA}	dB	68
External sound level according to ISO 6395 and EU Noise Directive 2000/14/EC		
L _{WA}	dB	105

Service Refill

Service accessibility: Large, electrically operated easy-to-open hood covering whole engine compartment. Fluid filters and component breather air filters are located from ground level access and promote long service intervals. Machine contronics have possibility to monitor, log and analyze data to facilitate troubleshooting. A quick-fit adapter on the hydraulic tank provides faster hydraulic oil fill.

Fuel tank	l (gal)	222 (58.6)
DEF/AdBlue® tank	l (gal)	20 (5.3)
Engine coolant	l (gal)	30 (7.9)
Hydraulic oil tank	l (gal)	90 (23.8)
Transmission oil (non lock-up)	l (gal)	21 (5.5)
Transmission oil (lock-up)	l (gal)	22 (5.8)
Engine oil	l (gal)	20 (5.2)
Axle oil front	l (gal)	35 (9.2)
Axle oil rear	l (gal)	27 (7.1)

Hydraulic system

Closed center load sensing hydraulic system with non pressurised hydraulic tank and pilot operated control valves.

System supply: Variable displacement axial piston pump supply the hydraulic system.

Valves: The central valve distributes pressure and flow out to the cooling fan, steering, brake, pilot and hydraulic system. Steering system gets priority over others.

Lift function: The valve has four positions; raise, hold, lower and float position. Automatic boom kickout position can be set to any position between maximum reach and full lifting height.

Tilt function: The valve has three functions; rollback, hold and dump. Automatic tilt out/tilt in can be adjusted to the desired bucket angle.

Cylinders: Double-acting cylinders for all functions.

Filter: Full flow filtration through 10 micron (absolute) filter cartridge.

Working pressure maximum, pump 2 for steering-, brake-, pilot- and working hydraulic system	MPa (bar)	26 (260)
---	-----------	----------

Flow	l/min (gal/min)	154 (407)
at	MPa (bar)	10 (100)
engine speed	r/min (r/s)	1,900 (317)

Working pressure maximum, pump 3 for brake- and cooling fan system	MPa (bar)	21 (210)
--	-----------	----------

Flow	l/min (gal/min)	33 (87)
at	MPa (bar)	10 (100)
engine speed	r/min (r/s)	1,900 (317)

Pilot system, working pressure	MPa (bar)	3.5 (35)
--------------------------------	-----------	----------

Cycle times		
Lift	s	55
Tilt	s	21
Lower, empty	s	29
Total cycle time	s	105

Drivetrain

Torque converter: Single-stage

Transmission: Volvo countershaft transmission with single lever control. Fast and smooth shifting of gears with Pulse Width Modulation (PWM) valve.

Transmission: Volvo Automatic Power Shift (APS) gear shifting system with fully automatic shifting 1-4 and mode selector with 4 different gear shifting programs, including AUTO mode. Also equipped with Rimpull control to avoid wheel spin and optimize bucket filling.

Axles: Volvo fully floating axle shafts with planetary hub reductions and cast steel axle housing. Fixed front axle and oscillating rear axle. 100% differential lock on the front axle.

Transmission	Volvo:	HTE 125C Non Lock-up/ HTE 125 Lock-up
--------------	--------	--

Torque multiplication, stall ratio		2.5:1 Non Lock-up/ 2.59:1 Lock-up
------------------------------------	--	--------------------------------------

Maximum speed

1st gear	km/h (mi/h)	Converter 7.5 / Lock-up 7.5 (Converter 4.6 / Lock-up 4.6)
----------	-------------	--

2nd gear	km/h (mi/h)	Converter 15 / Lock-up 15 (Converter 9.3 / Lock-up 9.3)
----------	-------------	--

3rd gear	km/h (mi/h)	Converter 29 / Lock-up 30 (Converter 17.4 / Lock-up 18.0)
----------	-------------	--

4th gear	km/h (mi/h)	Converter 46 / Lock-up 50 (Converter 28.5 / Lock-up 31.1)
----------	-------------	--

4th gear: Shown in speedometer and limited by ECU

Measured with tires	20.5R25
---------------------	---------

Front axle/rear axle	AWB 25/AWB 20
----------------------	---------------

Rear axle oscillation	± °	13
-----------------------	-----	----

Ground clearance	mm (in)	470 (185)
------------------	---------	-----------

at oscillation	°	13
----------------	---	----



Specifications

Tires 20.5 R25 L3

		L70H			
		Standard boom		Long boom	
B	mm ft in	6,080	19'11"	6,560	21'6"
C	mm ft in	3,000	9'10"	3,000	9'10"
D	mm ft in	450	1'6"	450	1'6"
F	mm ft in	3,280	10'9"	3,280	10'9"
G	mm ft in	2,134	7'0"	2,134	7'0"
J	mm ft in	3,580	11'9"	4,050	13'3"
K	mm ft in	3,870	12'8"	4,350	14'3"
O	°	56		52	
P _{max}	°	46		45	
R	°	43		44	
R ₁ *	°	48		49	
S	°	68		73	
T	mm ft in	106	0'4"	112	0'4"
U	mm ft in	450	1'6"	500	1'8"
X	mm ft in	1,930	6'4"	1,930	6'4"
Y	mm ft in	2,460	8'1"	2,460	8'1"
Z	mm ft in	3,160	10'4"	3,500	11'6"
a ₂	mm ft in	5,350	17'7"	5,350	17'7"
a ₃	mm ft in	2,890	9'6"	2,890	9'6"
a ₄	±°	40		40	

* Carry position SAE

Calculated with additional protective guarding

Where applicable, specifications and dimensions are according to ISO 7131, SAE J732, ISO 7546, SAE J742, ISO 14397, SAE J818

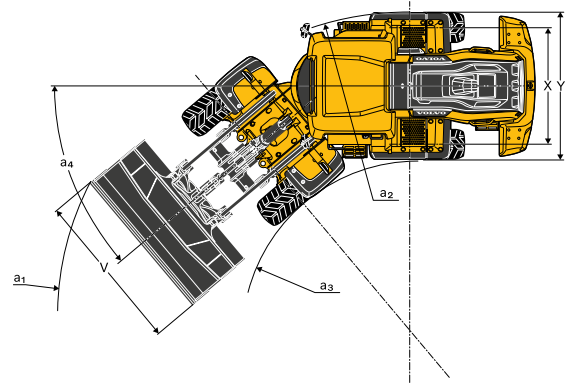
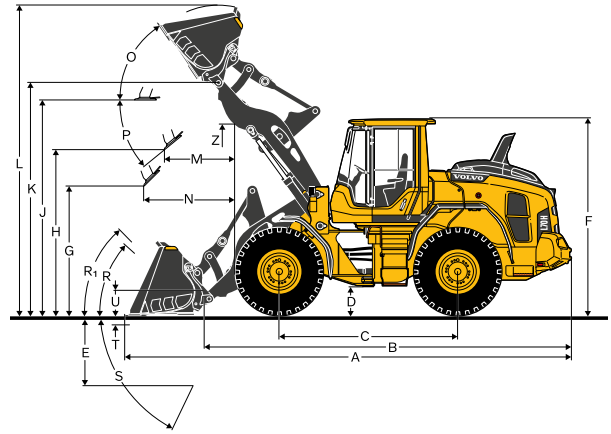

Tires: 20.5R25 L3

		L70H	
SAE-Load	kg lb	3,990	8,796
Operating weight without load*	kg lb	14,585	32,154
Grapple sales code		WLA80153	
A	m ² yd ²	1.5	1.8
B	mm ft in	3,380	11'1"
C	mm ft in	1,594	5'3"
D	mm ft in	2,870	9'5"
E	mm ft in	1,265	4'2"
F	mm ft in	1,502	4'11"
G	mm ft in	2,442	8'0"
H	mm ft in	4,378	14'4"
I	mm ft in	6,027	19'9"
J	mm ft in	2,141	7'0"
K	mm ft in	2,365	7'9"
L	mm ft in	1,800	5'11"
M	mm ft in	7,996	26'3"

* Calculated with additional protective guarding

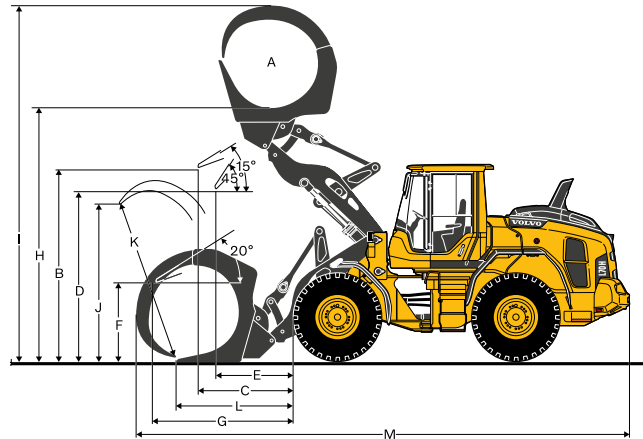

Tires: 20.5R25 L3

		L70H	
Material handling arm sales code		92007	
A*	kg lb	2,150	4,740
B*	kg lb	1,710	3,770
C*	kg lb	1,400	3,086
Static tipping load, straight	kg lb	3,583	7,899
35deg. Turn	kg lb	3,222	7,103
at full turn	kg lb	3,116	6,870
D	mm ft in	2,716	8'11"
E	mm ft in	2,106	6'11"
F	mm ft in	1,549	5'1"
G	mm ft in	3,323	10'11"
H	mm ft in	4,358	14'4"
I	mm ft in	5,492	18'0"
J	mm ft in	1,269	4'2"
K	mm ft in	1,744	5'9"
L	mm ft in	2,266	7'5"
M	mm ft in	2,176	7'2"
N	mm ft in	3,095	10'2"
O	mm ft in	4,102	13'5"
P	mm ft in	1,523	5'0"
Q	mm ft in	5,302	17'5"
R	mm ft in	6,174	20'3"
S	mm ft in	7,129	23'5"
Operating weight without load	kg lb	13,451	29,654

* Op. load at full turn + tipping position

Tipping loads calculated for max. arm length

**Calculated with additional protective guarding

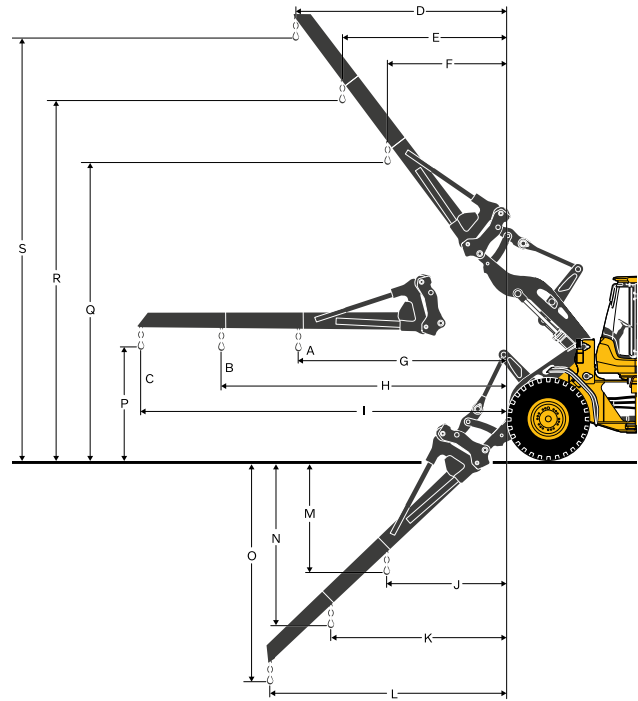

Tires: 20.5R25 L3

		L70H	
Fork frame sales code		83768	
Fork tines sales code (R/L)		80042/80044	
Static tipping load, straight	kg lb	7,576	16,702
35deg. Turn	kg lb	6,809	15,011
at full turn	kg lb	6,584	14,515
at load center distance*	mm ft in	600	2'0"
A	mm ft in	841	2'9"
B	mm ft in	1,616	5'4"
C	mm ft in	-52	-1'10"
D	mm ft in	1,859	6'1"
E	mm ft in	3,736	12'3"
F	mm ft in	767	2'6"
Operating weight without load	kg lb	13,531	29,831

* Firm and level ground

**Calculated with additional protective guarding

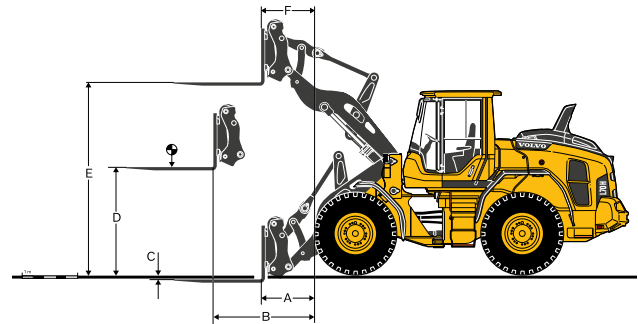

Specifications

L70H* MICH 20.5R25 XHA2 L3	GENERAL PURPOSE												GRADING		LIGHT MATERIAL		LONG BOOM**						
	WLA87535	WLA86405	WLA86401	WLA86404	WLA86407	WLA86413	WLA92477	WLA80562	WLA80634	WLA86413													
Volume, heaped ISO/SAE	m ³	2.3	3.0	2.2	2.9	2.0	2.6	2.2	2.9	2.3	3.0	2.2	2.9	2.2	2.9	2.2	2.9	3.4	4.4	6.4	8.4	2.2	2.9
Volume at 110% fill factor	m ³	2.5	3.3	2.4	3.2	2.2	2.9	2.4	3.2	2.5	3.3	2.4	3.2	2.4	3.2	3.7	4.9	7.0	9.2	2.4	3.2		
Static tipping load, straight	kg	9,740	21,480	9,840	21,710	9,770	21,550	9,710	21,410	9,670	21,320	10,310	22,730	7,920	17,470	9,253	20,400	8,830	19,460	-1,550	-3,400		
at 35° turn	kg	8,710	19,200	8,810	19,420	8,740	19,270	8,680	19,130	8,640	19,050	9,240	20,370	7,040	15,530	8,246	18,180	7,790	17,180	-1,430	-3,140		
at full turn	kg	8,400	18,530	8,500	18,740	8,430	18,590	8,370	18,460	8,340	18,380	8,920	19,680	6,780	14,950	7,949	17,530	7,490	16,510	-1,390	-3,070		
Breakout force	kN	87.8	19,740	91.3	20,520	92.8	20,860	88.5	20,110	87.6	19,690	98.7	22,200	62.7	14,090	71.7	16,130	53.9	12,110	-1.8	-410		
A	mm	7,510	24' 8"	7,700	25' 3"	7,440	24' 5"	7,490	24' 7"	7,520	24' 8"	7,370	24' 2"	7,950	26' 1"	7,776	25' 6"	8,330	27' 4"	+470	+1' 7"		
E	mm	1,210	4' 0"	1,360	4' 6"	1,140	3' 9"	1,190	3' 11"	1,210	4' 0"	1,080	3' 6"	1,670	5' 6"	1,466	4' 10"	1,960	6' 5"	+20	+0' 1"		
H	mm	2,740	9' 0"	2,620	8' 7"	2,790	9' 2"	2,760	9' 0"	2,740	9' 0"	2,830	9' 3"	2,360	7' 9"	2,531	8' 4"	2,160	7' 1"	+490	+1' 8"		
L	mm	5,170	16' 11"	5,220	17' 1"	5,110	16' 9"	5,170	17' 0"	5,200	17' 1"	5,100	16' 9"	4,720	15' 6"	5,455	17' 11"	5,790	19' 0"	+470	+1' 6"		
M	mm	1,160	3' 10"	1,270	4' 2"	1,110	3' 8"	1,140	3' 9"	1,160	3' 10"	1,060	3' 6"	1,350	4' 5"	1,339	4' 5"	1,720	5' 8"	+20	+0' 1"		
N	mm	1,660	5' 5"	1,690	5' 7"	1,640	5' 4"	1,650	5' 5"	1,660	5' 5"	1,610	5' 3"	1,570	5' 2"	1,680	5' 6"	1,720	5' 8"	+390	+1' 4"		
V	mm	2,650	104"	2,500	98"	2,650	104"	2,650	104"	2,650	104"	2,650	104"	2,650	104"	2,650	104"	2,750	108"	0	0'		
a ₁ clearance circle	mm	11,800	38' 8"	11,750	38' 7"	11,760	38' 7"	11,790	38' 8"	11,800	38' 9"	11,740	38' 6"	12,320	40' 5"	11,980	39' 4"	12,410	40' 9"	+370	+1' 3"		
Operating weight	kg	13,950	30,760	13,920	30,700	13,950	30,770	13,990	30,840	14,000	30,880	13,720	30,260	14,240	31,400	14,193	31,290	14,730	32,490	+510	+1,120		

*Calculated with additional protective guarding. (WL86009,WL86010)

**Calculated with logging counterweight.

Note: This only applies to genuine Volvo attachments.

Bucket Selection Chart

The chosen bucket is determined by the density of the material and the expected bucket fill factor. The actual bucket volume is often larger than the rated capacity, due to the features of the TP linkage, including an open bucket design, good rollback angles in all positions and good bucket filling performance. The example represents a standard boom configuration.
Example: Sand and gravel. Fill factor ~ 105%. Density 1.55 t/m³ (2,610 lb/yd³). Result: The 2.6 m³ (3.4 yd³) bucket carries 2.7m³ (3.5 yd³). For optimum stability always consult the bucket selection chart.

Material	Bucket fill, %	Material density		ISO/SAE bucket volume		Actual volume	
		t/m ³	lb/yd ³	m ³	yd ³	m ³	yd ³
Earth/ Clay	~ 110	~ 1.55	~ 2,610	2.5	3.3	2.7	3.5
		~ 1.45	~ 2,440	2.6	3.4	2.9	3.8
		~ 1.40	~ 2,360	2.8	3.7	3.1	4.0
Sand/ Gravel	~ 105	~ 1.65	~ 2,780	2.5	3.3	2.6	3.4
		~ 1.55	~ 2,610	2.6	3.4	2.7	3.5
		~ 1.50	~ 2,530	2.8	3.7	2.9	3.7
Aggregate	~ 100	~ 1.75	~ 2,950	2.5	3.3	2.5	3.3
		~ 1.65	~ 2,780	2.6	3.4	2.6	3.4
		~ 1.60	~ 2,700	2.8	3.4	2.8	3.7
Rock	≤100	~ 1.80	~ 3,030	2.2	2.9	2.2	2.9

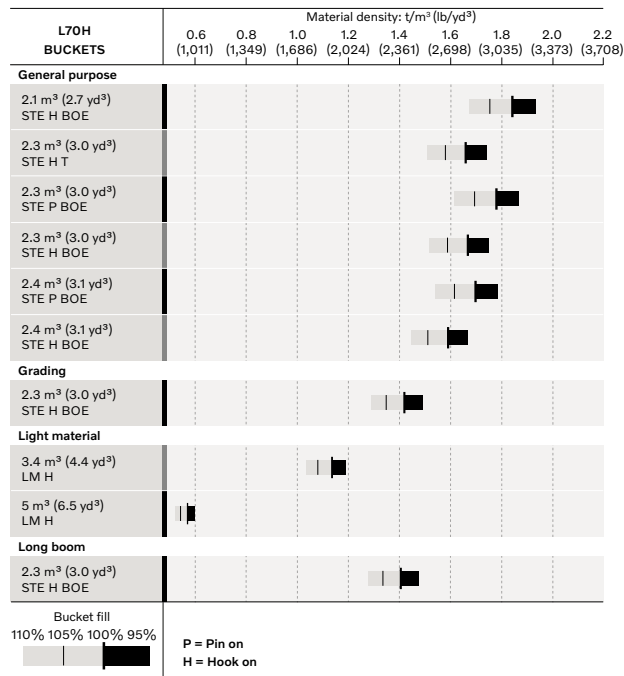

How to read bucket fill factor

Supplemental Operating Data

Tires 20.5 R25 L3					20.5 R25 L2		600/65 R25 L3		Long boom 600/65 R25 L3	
	mm	in	mm	in	mm	in	mm	in	mm	in
Width over tires					+8	+0.3	+96	+3.8	+96	+3.8
Ground clearance					-10	-0.4	-30	-1.2	-22	-0.9
Tipping load, full turn	kg	lb	kg	lb	-166	-366	-72	-159	0	0
Operating weight	kg	lb	kg	lb	-112	-247	+8	+18	+3	+7

Calculated with 2.3 m³ (3.0 yd³) STE P BOE, additional protective guarding

Equipment

STANDARD EQUIPMENT

Engine

Exhaust after-treatment system
3-stage air cleaner, pre-cleaner, primary and secondary filter
Indicator glass for coolant level
Preheating of induction air
Fuel pre-filter with water trap
Fuel filter
Crank case breather oil trap
Exhaust heat ventilation

Tires

20.5R25

Drivetrain

Automatic Power Shift
Fully automatic gear shifting, 1-4
PWM-controlled gear shifting
Forward and reverse switch by hydraulic lever console
Rimpull control
Indicator glass for transmission oil level
Differentials: Front, 100% hydraulic diff lock. Rear, conventional

Electrical System

24 V, pre-wired for optional accessories
Alternator 80A/3135W
Battery disconnect switch
Maintenance-free batteries
Battery box, steel
Fuel gauge
Electric horn
Instrument cluster:
Fuel level
Diesel Exhaust Fluid/AdBlue level
Transmission temperature
Coolant temperature
Instrument lighting
Lighting:
Twin halogen front headlights with high and low beams
Parking lights
Double brake and tail lights
Turn signals with flashing hazard light function
Halogen work lights (2 front and 2 rear)

STANDARD EQUIPMENT

Contronic monitoring system

Contronic display
Fuel consumption
Diesel Exhaust Fluid/AdBlue consumption
Ambient temperature
Clock
Test function for warning and indicator lights
Brake test
Warning and indicator lights:
Battery charging
Parking brake
Warning and display message:
Regeneration
Engine coolant temperature
Charge air temperature
Engine oil temperature
Engine oil pressure
Transmission oil temperature
Transmission oil pressure
Hydraulic oil temperature
Brake pressure
Parking brake applied
Brake charging
Overspeed at direction change
Axle oil temperature
Steering pressure
Crank case pressure
Attachment lock open
Level warnings:
Fuel level
Diesel Exhaust Fluid/AdBlue level
Engine coolant level
Transmission oil level
Hydraulic oil level
Washer fluid level
Engine torque reduction in case of malfunction indication:
High engine coolant temperature
High engine oil temperature
Low engine oil pressure
High crank case pressure
High charge air temperature
Engine shutdown to idle in case of malfunction indication:
High transmission oil temperature
Slip in transmission clutches
Key pad, background lit
Start interlock when gear is engaged

Hydraulic system

Main valve, double acting 2-spool with hydraulic pilots
Variable displacement axial piston pumps (2) for:
Working hydraulics, pilot hydraulics, steering system, brakes
Cooling fan, brakes
Hydraulic control levers
Mechanical hydraulic lever lock
Automatic boom kick-out
Automatic bucket positioner
Double acting hydraulic cylinders
Indicator glass for hydraulic oil level
Hydraulic oil cooler
Brake system
Dual brake circuits
Dual brake pedals
Secondary brake system
Parking brake, electrical-hydraulic
Brake wear indicators
Outboard mounted circulating oil cooled wet disc brakes on all four wheels

Equipment

STANDARD EQUIPMENT

Cab

Volvo Copilot with Rearview camera standard
ROPS (ISO 3471), FOPS (ISO 3449)
Single key kit door/start
Acoustic inner lining
Cigarette lighter, 24 V power outlet
Lockable door
Cab heating with fresh air inlet and defroster
Fresh air inlet with two filters
Automatic heat control
Floor mat
Dual interior lights
Interior rearview mirrors
Dual exterior rearview mirrors
Sliding window, right side
Tinted safety glass
Retractable seatbelt (SAE J386)
Adjustable steering wheel
Storage compartment
Document pocket
Sun visor
Beverage holder
Windshield washer front and rear
Windshield wipers front and rear
Interval function for front and rear wipers
Foot step, left side (toolbox lockable included)
ACC control panel, with Fahrenheit scale
Anchorage for Operator's manual
Service and maintenance
Engine oil remote drain and fill
Transmission oil remote drain and fill
Sliding hydraulic oil cooler and AC-condenser
Lubrication manifolds, ground accessible
Pressure test ports: transmission and hydraulic, quick connects
Service platforms with anti-slip surfaces
Quick-fit hydraulic oil fill
CareTrack
Telematics, 6 -year subscription
Toolbox, lockable
External equipment
Basic fenders, front and rear
Viscous cab mounts
Rubber engine and transmission mounts
Engine hood, electronically openable
Frame, joint lock
Vandalism lock for engine compartment
Lifting eyes
Tie down eyes
Tow hitch
Counterweight, pre-drilled for optional guards

OPTIONAL EQUIPMENT

Engine

Air pre-cleaner, cyclone type
Air pre-cleaner, oil-bath type
Air pre-cleaner, turbo type
Engine auto shut down
Engine block heater, 120V / 230V
Fuel heater
Fuel fill strainer
Hand throttle control
Max. fan speed, hot climate
Reversible cooling fan
Drivetrain
Lock-up torque converter
Rear axle with limited slip
Speed limiter, 20 km/h
Speed limiter, 30 km/h
Speed limiter, 40 km/h

OPTIONAL EQUIPMENT

Hydraulic system

Arctic kit: Attachment locking, pilot hoses and hydraulic oil
Attachment bracket, cast, visibility-optimized
Attachment bracket, side-tilting
Separate attachment locking, long boom
Separate attachment locking, standard boom
Single acting lifting function
Boom suspension system
HD load-sensing hydraulics, pump kit included
Hydraulic fluid, biodegradable, Volvo
Hydraulic fluid, fire resistant
Hydraulic fluid, for hot climate
Hydraulic, 2 functions Electro-servo, std/long boom
Hydraulic, 3 functions Electro-servo, std/long boom
Hydraulic, 4 functions Electro-servo, std/long boom
Single lever control, 2 funct Electro-servo, std/long boom
Single lever control, 3 funct Electro-servo, std/long boom
Single lever control, 4 funct Electro-servo, std/long boom

Brake system

Parking brake alarm, audible
Stainless steel, brake lines
Axle oil cooler

Cab

Asbestos dust protection filter
Automatic Climate Control, ACC
Automatic Climate Control, ACC, corrosion protection condenser
Cab air pre-cleaner, cyclone type
Carbon filter - cab
Remote door opener
Lunch box holder
Operator's seat, Volvo air-suspended, heavy-duty, high back, heated
Operator's seat, Volvo air-susp, 3-point seatbelt
Operator's seat, Premium Comfort ISRI
Operator's seat, Premium Comfort ISRI 3-point seat belt
Armrest, operator's seat, ISRI, left only
Armrest, operator's seat, Volvo, left
Safety belt, 3" (75mm) width
Safety belt warning
Radio installation kit including 12 volt outlet, left-side
Radio installation kit including 12 volt outlet, right-side
Radio installation kit, 12V, for USA
Radio with AUX, Bluetooth and USB connection
DAB Radio
Subwoofer
Forward view mirror
Rear view mirrors, el.adjusted and heated
Rear view mirrors, long arm right
Rear view mirrors, el.adjusted and heated, long arm right
Steering wheel knob
Sun blinds, rear windows
Sun blinds, side windows
Timer cab heating
Universal door/ignition key
Window, sliding, door
Cab, Hot applications. Roof, steel
Fire extinguisher cab
Outside steel protection cab
Rear view mirrors long arm, cab
Reinforced windshield, flat
Service and maintenance
Automatic lubrication system
Automatic lubrication system for long boom
Oil sampling valve
Refill pump for automatic lubrication system
Tool kit
Wheel nut wrench kit

OPTIONAL EQUIPMENT

Electrical

Battery disconnect switch, additional in cab
Anti-theft device
Headlights, assym. left
Headlights, assym. right LED
Headlights, assym. left LED
Emergency stop
License plate holder, lighting
Reduced function working lights when reverse gear activated
Side marker lamps
Forward camera, colour
Rear view mirrors, long arm, right side
Rearview mirrors, adjustable, el. heated
Reverse alarm
Reverse lights
Reversing warning light
Reverse warning light, strobe lightning
Warning beacon (flasher), LED automatic
Warning beacon (flasher), LED
Seatbelt indicator, external
Working lights, attachments, 1 LED
Warning beacon LED
Warning beacon LED automatic
LED Head Light
LED tail light
LED working lights, attachments
LED working lights on cab, front and rear
LED working lights on cab, front, 2 alt. 4 LED lamps
LED working lights on cab, rear, 2 alt. 4 LED lamps
LED working lights, rear in grille, 2 LED lamps
LED working lights, front above head lamps, 2 LED lamps
LED work lights, side on cab, 4 LED lamps
LED light packages
Working lights halogen, attachments
Working lights on cab halogen, front and rear
Working lights on cab halogen, rear
Co Pilot available
Rearview camera in Co pilot
Max Boom height
Can Bus Interface
Delayed Engine Shutdown

Protective equipment

Anti-theft device
Bellyguard front
Bellyguard rear
Boom cylinder hose and tube guards
Cab roof, heavy duty
Center hinge and rear frame guard
Corrosion protection, painting of machine
Cover plate front frame, heavy-duty
Cover plate, under cab
Cover plates rear frame
Guards for front headlights
Grease nipple guards
Guards for radiator grill
Guards for tail lights, heavy-duty
Wheel/axle seal guards
Window guards, side and rear
Windshield guard

OPTIONAL EQUIPMENT

External equipment

Deleted front mudguards
Fire extinguisher
Bracket for fire extinguisher
Fire suppression system
Mudguards, full cover, rear for 80-series tires
Mudflap kit for mudguards, full cover for 80-series tires
Mudguards, full cover, rear and front/rear for 65-series tires
Mudflap kit for mudguards, full cover for 65-series tires
Footsteps front frame
Footsteps, right-hand side
Flexible rear step
Cab ladder, rubber suspended

Other equipment

CareTrack, GSM/Satellite
CE-marking
Comfort Drive Control (CDC) Electro-servo
Secondary steering
Counterweight, logging
Counterweight, signal painted, chevrons
Option for machines without dinitrol
Noise reduction kit, EU excluding decal
Sign, 50 km/h
Sign, slow moving vehicle

Tires and Rims

20.5R25
600/65R25
620/75R26 Agriculture application only
750/65R26 Agriculture application only

Attachments

Buckets:
Straight
Spade nose
High tipping
Light material
Grading
Wear parts:
Bolt-on edge
Bolt-on or weld-on bucket teeth
Segments
Log grapples
Fork equipment
Material handling arm
Snow blade
Broom
Sand spreading bucket

Not all products are available in all markets. Under our policy of continuous improvement, we reserve the right to change specifications and design without prior notice. The illustrations do not necessarily show the standard version of the machine.

V O L V O