

V O L V O



Volvo Wheel Loaders 11.0-13.6 t / 24,250-29,980 lb 164 hp

# L60H

Volvo Construction Equipment

# L60H

Leave the heavy-duty work for the L60H, designed to do more, be more comfortable and help you increase your productivity.



# Designed to do more

Hard work has never felt so easy. H-Series wheel loaders are built with an industry-leading, strong frame, which, combined with the ideally-matched genuine Volvo drivetrain, achieves long-lasting performance. And with the help of a range of smart apps you can boost the efficiency of your operation from the comfort of the cab.



## Loaded with versatility

- Torque Parallel linkage
- Volvo attachment bracket
- Range of purpose-built attachments
- Rehandling bucket
- 3rd and 4th hydraulic functions



## Keep it moving

- Quick hydraulic oil fill thanks to new mounted nipple
- Improved cooling capacity
- Strong frame and central hinge
- Standard delayed engine shutdown
- Optional Load Assist Tire Pressure monitoring



## Safety as standard

- Anti-slip steps and strategically placed handrails
- Orange three-point seatbelt
- Redesigned side mirrors
- Rear-view camera



## Strong and stable

- Optimized loading unit weight, heavyduty counterweight for greater stability
- Standard electro-servo controls
- Auto Bucket leveling function
- Lifetime Frame warranty



## Increased productivity

- Optional lock-up converter
- Rimpull control
- Smart Control
- Smooth Control
- Eco pedal
- Load Assist On-Board Weighing hardware- Standard
- Load Assist Operator Coaching - Standard



## Greater access

- Cooler installation slides out for easier cleaning
- Repositioned fill spouts for transmission and engine oil
- Ground-level access to service points
- Electronically-operated engine hood

# Volvo L60H in detail

## Engine

6-cylinder, 6 liters inline turbocharged diesel engine with an advanced fuel injection system with the common rail. Fuel is distributed under high pressure from a high-pressure accumulator, the rail. One belt driven high pressure pump deliver the fuel to the rail and then further on via high-pressure pipes to the electronically operated fuel injectors. Engine meets Tier 4f / EU Stage V emission legislation.

Engine	Volvo	D6J
Max. power at	r/min (r/s)	1,500 - 1,800 (25 - 30)
ISO 14396 gross	kW (hp)	122 (164)
ISO 9249, SAE J1349 net	kW (hp)	122 (164)
Max. torque at	r/min (r/s)	1,400 (23)
ISO 14396 gross	Nm (ft lbf)	820 (605)
ISO 9249, SAE J1349 net	Nm (ft lbf)	820 (605)
Economic working range	r/min (r/s)	800 - 1,600 (13.3 - 26.7)
Displacement	l (in <sup>3</sup> )	5.7 (348)

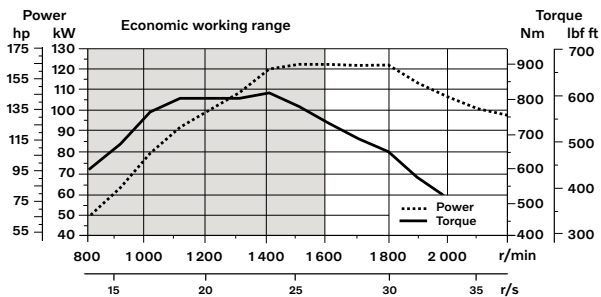

## Electrical system

Contronic electrical system with central warning light and buzzer for following functions: - Serious engine fault, Low steering system pressure, Over speed warning engine, Interruption in communication (computer fault), Central warning light and buzzer with the gear engaged for the following functions: Low engine oil pressure, High engine oil temperature, High charge air temperature, Low coolant level, High coolant temperature, High crank case pressure, Low transmission oil pressure, High transmission oil temperature, Low brake pressure, Engaged parking brake, Fault on brake charging, Low hydraulic oil level, High hydraulic oil temperature, Overspeeding in engaged gear, High brake cooling oil temperature front and rear axles, etc.

Batteries	V	2 x 12
Battery capacity	Ah	2 x 110
Cold cranking capacity, approx	A	1,000
Alternator rating	W/A	3,135/80
Starter motor output	kW	5.5

## Brake system

**Service brake:** Volvo dual-circuit system with outboard mounted, hydraulically operated, fully sealed and circulating oil cooled wet disc brakes. Four operator selectable transmission disengagement settings while braking.

**Parking brake:** Dry disc brake mounted on the transmission output shaft. Applied by spring force, electro-hydraulically released with a switch on the instrument panel.

**Secondary brake:** Dual brake circuits with rechargeable accumulators.

**Standard:** The brake system complies with the requirements of ISO 3450, 71/320/EEC

Number of brake discs per wheel		1
Accumulators	l (gal)	3 x 0.5 (3 x 0.13)
Accumulators for parking brake	l (gal)	1 x 0.5 (1 x 0.13)

## Lift Arm System

Torque parallel linkage (TP-linkage) with high breakout torque and parallel lift-arm action.

Lift cylinders		2
Cylinder bore	mm (in)	110 (4.3)
Piston rod diameter	mm (in)	70 (2.8)
Stroke	mm (in)	665 (26.2)
Tilt cylinder		1
Cylinder bore	mm (in)	150 (5.9)
Piston rod diameter	mm (in)	80 (3.1)
Stroke	mm (in)	444 (17.5)

## Steering System

**System supply:** The steering system has priority feed from a load-sensing axial piston pump with variable displacement.

**Steering cylinders:** Two double-acting cylinders.

Steering cylinders		2
Cylinder bore	mm (in)	70 (2.8)
Rod diameter	mm (in)	45 (1.8)
Stroke	mm (in)	386 (15.2)
Working pressure	MPa (bar)	21 (210)
Maximum flow	l/min (gal/min)	60 (15.9)
Maximum articulation	± °	40

## Cab

**Instrumentation:** All important information is centrally located in the operator's field of vision. Display for Contronic monitoring system.

**Heater and defroster:** Heater coil with filtered fresh air and fan with auto and manual settings (11 speeds). Defroster vents for all window areas.

**Operator's seat:** Operator's seat with adjustable air suspension and retractable seatbelt. The seat is mounted on a bracket on the rear cab wall and floor. The forces from the retractable seatbelt are absorbed by the seat rails.

**Standards:** The cab is tested and approved according to ROPS (ISO 3471, SAE J1040), FOPS (ISO 3449). The cab meets with requirements according to SAE J386 („Operator Restraint System“). Refrigerant of the type R134a is used when this machine is equipped with air conditioning. Contains fluorinated greenhouse gas R134a, Global Warming Potential 1.430 t CO<sub>2</sub>-eq.

**Emergency exit:** Use emergency hammer to break window

Ventilation	m <sup>3</sup> /min (yd <sup>3</sup> /min)	9 (11.8)
Heating capacity	kW	16
Air conditioning (optional)	kW	7.5

## Sound Level

Sound pressure level in cab according to ISO 6396

L <sub>pA</sub>	dB	68
External sound level according to ISO 6395		
L <sub>WA</sub>	dB	104

## Service Refill

**Service accessibility:** Large, electrically operated easy-to-open hood covering whole engine compartment. Fluid filters and component breather air filters are located from ground level access and promote long service intervals. Machine contronics have possibility to monitor, log and analyze data to facilitate troubleshooting. A quick-fit adapter on the hydraulic tank provides faster hydraulic oil fill.

Fuel tank	l (gal)	222 (58.6)
DEF/AdBlue® tank	l (gal)	20 (5.3)
Engine coolant	l (gal)	30 (7.9)
Hydraulic oil tank	l (gal)	90 (23.8)
Transmission oil (non lock-up)	l (gal)	21 (5.5)
Transmission oil (lock-up)	l (gal)	22 (5.8)
Engine oil	l (gal)	20 (5.2)
Axle oil front	l (gal)	25 (6.6)
Axle oil rear	l (gal)	25 (6.6)

## Hydraulic system

Closed center load sensing hydraulic system with non pressurised hydraulic tank and pilot operated control valves.

**System supply:** Variable displacement axial piston pump supply the hydraulic system.

**Valves:** The central valve distributes pressure and flow out to the cooling fan, steering, brake, pilot and hydraulic system. Steering system gets priority over others.

**Lift function:** The valve has four positions; raise, hold, lower and float position. Automatic boom kickout position can be set to any position between maximum reach and full lifting height.

**Tilt function:** The valve has three functions; rollback, hold and dump. Automatic tilt out/tilt in can be adjusted to the desired bucket angle.

**Cylinders:** Double-acting cylinders for all functions.

**Filter:** Full flow filtration through 10 micron (absolute) filter cartridge.

Working pressure maximum, pump 2 for steering-, brake-, pilot- and working hydraulic system	MPa (bar)	26 (260)
---	-----------	----------

Flow	l/min (gal/min)	145 (38.3)
at	MPa (bar)	10 (100)
engine speed	r/min (r/s)	1,900 (31.7)

Working pressure maximum, pump 3 for brake- and cooling fan system	MPa (bar)	21 (210)
--	-----------	----------

Flow	l/min (gal/min)	33 (8.7)
at	MPa (bar)	10 (100)
engine speed	r/min (r/s)	1,900 (31.7)
Pilot system, working pressure	MPa (bar)	3.5 (35)

Cycle times		
Lift	s	5.4
Tilt	s	1.9
Lower, empty	s	2.7
Total cycle time	s	10

## Drivetrain

**Torque converter:** Single-stage

**Transmission:** Volvo countershaft transmission with single lever control. Fast and smooth shifting of gears with Pulse Width Modulation (PWM) valve.

**Transmission:** Volvo Automatic Power Shift (APS) gear shifting system with fully automatic shifting 1-4 and mode selector with 4 different gear shifting programs, including AUTO mode. Also equipped with Rimpull control to avoid wheel spin and optimize bucket filling.

**Axes:** Volvo fully floating axle shafts with planetary hub reductions and cast steel axle housing. Fixed front axle and oscillating rear axle. 100% differential lock on the front axle.

Transmission	Volvo	HTE 125C Non Lock-up / HTE 125 Lock-up
Torque multiplication, stall ratio		2.5:1 Non Lock-up / 2.59:1 Lock-up

### Maximum speed

1st gear	km/h (mi/h)	Converter 7.5 / Lock-up 7.5 (Converter 4.6 / Lock-up 4.6)
2nd gear	km/h (mi/h)	Converter 15 / Lock-up 15 (Converter 9.3 / Lock-up 9.3)
3rd gear	km/h (mi/h)	Converter 28 / Lock-up 29 (Converter 17.4 / Lock-up 18.0)
4th gear	km/h (mi/h)	Converter 46 / Lock-up 50 (Converter 28.6 / Lock-up 31.1)

4th gear: Shown in speedometer and limited by ECU		
Measured with tires		20.5R25
Front axle/rear axle		AWB 15/AWB 15
Rear axle oscillation	± °	13
Ground clearance at oscillation	mm (in)	470 (18.5)
	°	13





# Specifications

## Tires 20.5 R25 L3

			L60H			
			Standard boom		Long boom	
B	mm	ft in	6,010	19'9"	6,520	21'5"
C	mm	ft in	3,000	9'10"	3,000	9'10"
D	mm	ft in	440	1'5"	430	1'5"
F	mm	ft in	3,270	10'9"	3,260	10'8"
G	mm	ft in	2,133	7'0"	2,134	7'0"
I	mm	ft in	1,855	6'1"	1,855	6'1"
J	mm	ft in	3,550	11'8"	4,080	13'5"
K	mm	ft in	3,870	12'8"	4,380	14'4"
O	°		56		56	
P <sub>max</sub>	°		45		42	
R	°		43		45	
R <sub>1</sub> *	°		46		50	
S	°		79		79	
T	mm	ft in	123	0'5"	150	0'6"
U	mm	ft in	410	1'4"	590	1'11"
X	mm	ft in	1,900	6'3"	1,900	6'3"
Y	mm	ft in	2,430	7'12"	2,430	7'12"
Z	mm	ft in	3,210	10'6"	3,590	11'9"
a <sub>2</sub>	mm	ft in	5,340	17'6"	5,340	17'6"
a <sub>3</sub>	mm	ft in	2,900	9'6"	2,900	9'6"
a <sub>4</sub>	±°		40		40	

\* Carry position SAE

Calculated with additional protective guarding

Where applicable, specifications and dimensions are according to ISO 7131, SAE J732, ISO 7546, SAE J742, ISO 14397, SAE J818

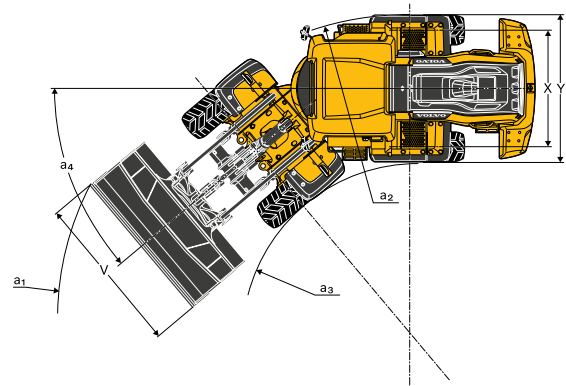
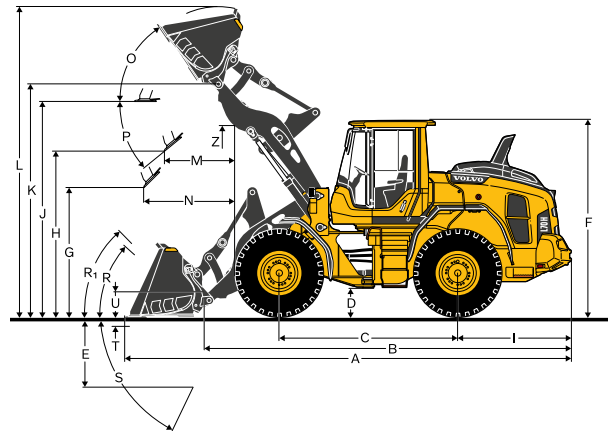

## Tires: 20.5R25 L3

			L60H	
SAE-Load	kg	lb	3,450	7,606
Operating weight without load*	kg	lb	12,883	28,402
Grapple sales code	WLA82194			
A	m <sup>2</sup>	yd <sup>2</sup>	1.3	1.6
B	mm	ft in	3,412	11'2"
C	mm	ft in	1,483	4'10"
D	mm	ft in	2,929	9'7"
E	mm	ft in	1,175	3'10"
F	mm	ft in	1,532	5'0"
G	mm	ft in	2,350	7'9"
H	mm	ft in	4,333	14'3"
I	mm	ft in	5,878	19'3"
J	mm	ft in	1,997	6'7"
K	mm	ft in	2,080	6'10"
L	mm	ft in	1,709	5'7"
M	mm	ft in	7,861	25'9"

\* Calculated with additional protective guarding

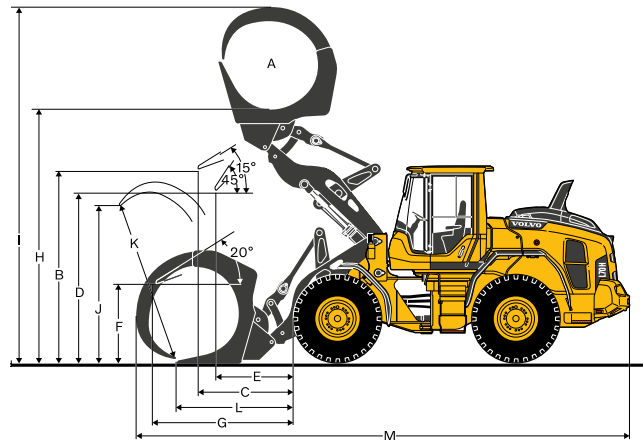

**Tires: 20.5R25 L3**

<b>L60H</b>				
Material handling arm sales code			92007	
A*	kg	lb	1,800	3,968
B*	kg	lb	1,400	3,086
C*	kg	lb	1,150	2,535
Static tipping load, straight	kg	lb	3,238	7,139
35deg. Turn	kg	lb	2,910	6,415
at full turn	kg	lb	2,814	6,204
D	mm	ft in	2,592	8'6"
E	mm	ft in	2,002	6'7"
F	mm	ft in	1,465	4'10"
G	mm	ft in	3,270	10'9"
H	mm	ft in	4,305	14'1"
I	mm	ft in	5,439	17'10"
J	mm	ft in	905	2'12"
K	mm	ft in	1,227	4'0"
L	mm	ft in	1,580	5'2"
M	mm	ft in	2,258	7'5"
N	mm	ft in	3,241	10'8"
O	mm	ft in	4,319	14'2"
P	mm	ft in	1,512	5'0"
Q	mm	ft in	5,286	17'4"
R	mm	ft in	6,171	20'3"
S	mm	ft in	7,139	23'5"
Operating weight without load	kg	lb	11,885	26,202

\* Op. load at full turn + tipping position

Tipping loads calculated for max. arm length

\*\*Calculated with additional protective guarding

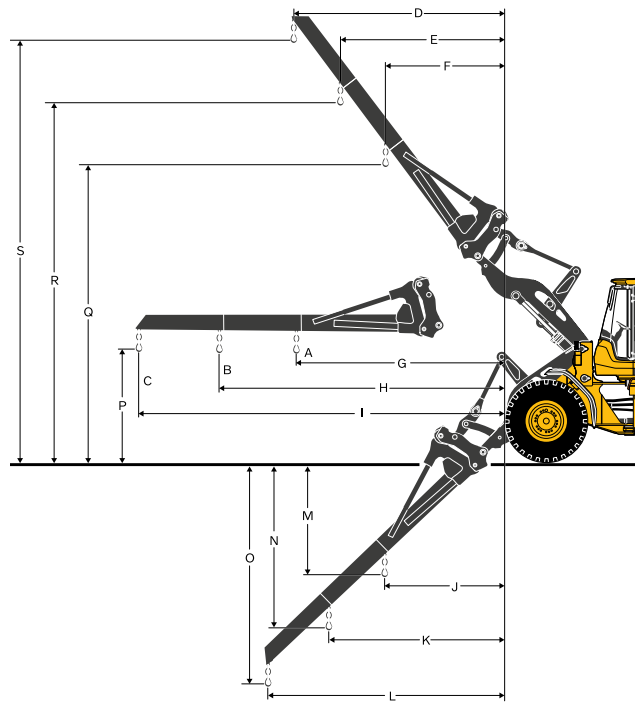

**Tires: 20.5R25 L3**







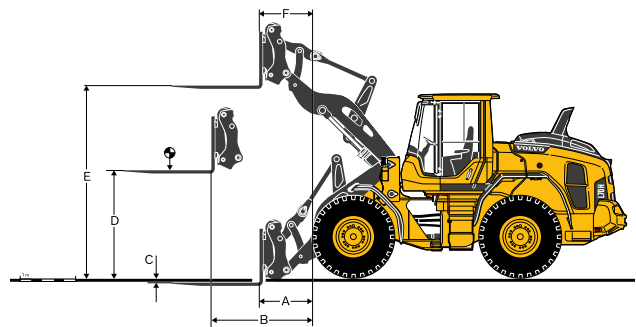



<b>L60H</b>				
Fork frame sales code			83768	
Fork tines sales code (R/L)			80042/80043	
Static tipping load, straight	kg	lb	6,930	15,278
35deg. Turn	kg	lb	6,230	13,735
at full turn	kg	lb	6,024	13,281
at load center distance*	mm	ft in	600	2'0"
A	mm	ft in	798	2'7"
B	mm	ft in	1,567	5'2"
C	mm	ft in	-38	-1'11"
D	mm	ft in	1,831	6'0"
E	mm	ft in	3,713	12'2"
F	mm	ft in	700	2'4"
Operating weight without load	kg	lb	11,965	26,378

\* Firm and level ground

\*\*Calculated with additional protective guarding



# Specifications

		REHANDLING <sup>(1)</sup>		GENERAL PURPOSE						GRADING		LIGHT MATERIAL		LONG BOOM <sup>(3)</sup>	
															
L60H* Tires 20.5 R25 L3		WLA54427685	WLA54427682	WLA86398	WLA86402	WLA86411	WLA86405	WLA92476	WLA92564	WLA92565					
		2.3 m <sup>3</sup> (3.0 yd <sup>3</sup> ) STE P BOE	2.3 m <sup>3</sup> (3.0 yd <sup>3</sup> ) STE H BOE	1.8 m <sup>3</sup> (2.4 yd <sup>3</sup> ) STE HT	2.1 m <sup>3</sup> (2.7 yd <sup>3</sup> ) STE H BOE	2.3 m <sup>3</sup> (3.0 yd <sup>3</sup> ) STE P BOE	2.3 m <sup>3</sup> (3.0 yd <sup>3</sup> ) STE H BOE	1.7 m <sup>3</sup> (2.2 yd <sup>3</sup> ) GRB H BOE	3.1 m <sup>3</sup> (4.1 yd <sup>3</sup> ) LM H BOE	5.0 m <sup>3</sup> (6.5 yd <sup>3</sup> ) LM H BOE					
Volume, heaped ISO/SAE	m <sup>3</sup> yd <sup>3</sup>	2.3 3	2.3 3	1.8 2.4	2.1 2.7	2.3 3	2.3 3	1.7 2.2	3.1 4.1	5.0 6.5	-	-	-	-	
Volume at 110% fill factor	m <sup>3</sup> yd <sup>3</sup>	2.5 3.3	2.5 3.3	2.0 2.6	2.3 3	2.5 3.3	2.5 3.3	1.9 2.4	3.4 4.5	5.5 7.2	-	-	-	-	
Static tipping load, straight	kg lb	9,130 20,140	8,690 19,150	8,800 19,400	8,580 18,920	8,950 19,740	8,490 18,730	7,500 16,540	8,190 18,060	8,190 18,050	-1,790	-3,940	-	-	
at 35° turn	kg lb	8,170 18,010	7,740 17,060	7,870 17,350	7,660 16,890	8,020 17,680	7,580 16,710	6,710 14,790	7,300 16,110	7,270 16,030	-1,650	-3,630	-	-	
at full turn	kg lb	7,880 17,380	7,460 16,450	7,600 16,750	7,390 16,290	7,740 17,070	7,310 16,110	6,470 14,280	7,040 15,530	7,000 15,440	-1,600	-3,530	-	-	
Breakout force	kN lbf	78.6 17,660	72.9 16,390	86.7 19,500	78.6 17,670	81. 18,220	75.3 16,930	60.3 13,550	61.8 13,900	53.8 12,110	8.3 1,850	-	-	-	
A Overall length	mm ft in	7,380 24'3"	7,490 24'7"	7,440 24'5"	7,380 24'3"	7,340 24'1"	7,440 24'5"	7,660 25'2"	7,690 25'3"	7,910 26'0"	520	+1'8"	-	-	
E Digging depth, max dump (S)	mm ft in	1,180 3'10"	1,280 4'2"	1,220 4'0"	1,180 3'10"	1,140 3'9"	1,230 4'1"	1,410 4'7"	1,490 4'11"	1,710 5'7"	40	+0'4"	-	-	
H <sup>(2)</sup> Dump clearance	mm ft in	2,770 9'1"	2,720 8'11"	2,750 9'0"	2,790 9'2"	2,800 9'2"	2,750 9'0"	2,510 8'3"	2,570 8'5"	2,430 8'0"	550	+1'10"	-	-	
L Overall operating height	mm ft in	5,230 17'2"	5,340 17'6"	5,020 16'6"	5,100 16'9"	5,110 16'9"	5,170 16'11"	4,520 14'10"	5,280 17'4"	5,480 18'0"	520	+1'8"	-	-	
M <sup>(2)</sup> Dump reach	mm ft in	1,070 3'6"	1,170 3'10"	1,130 3'8"	1,100 3'7"	1,040 3'5"	1,140 3'9"	1,130 3'8"	1,320 4'4"	1,500 4'11"	20	+0'1"	-	-	
N <sup>(2)</sup> Reach at 45° discharge, pos. G	mm ft in	1,590 5'3"	1,620 5'4"	1,600 5'3"	1,590 5'3"	1,580 5'2"	1,610 5'3"	1,480 4'10"	1,620 5'4"	1,670 5'6"	450	+1'6"	-	-	
V Bucket width	mm in	2,500 98"	2,500 98"	2,500 98"	2,500 98"	2,500 98"	2,500 98"	2,500 98"	2,550 100"	2,650 104"	0	+0'0"	-	-	
a <sub>1</sub> Outer clearance circle (diameter)	mm ft in	1,800 38'9"	1,830 38'10"	1,800 38'9"	1,770 38'7"	1,780 38'8"	1,800 38'9"	1,240 39'10"	1,200 39'5"	1,240 40'2"	480	+1'7"	-	-	
Operating weight without load	kg lb	12,100 26,680	12,380 27,300	12,020 26,500	12,120 26,730	11,870 26,180	12,170 26,830	12,010 26,480	12,200 26,910	12,490 27,540	230	500	-	-	

(1) Measured with additional counterweight.

(2) Measured to the tip of the bucket teeth or bolt-on edge. Dump height to bucket edge measured at 45° dump angle.

Note: This only applies to genuine Volvo attachments.

## Bucket Selection Chart

The chosen bucket is determined by the density of the material and the expected bucket fill factor. The actual bucket volume is often larger than the rated capacity, due to the features of the TP linkage, including an open bucket design, good rollback angles in all positions and good bucket filling performance. The example represents a standard boom configuration.

**Example:** Sand and gravel. Fill factor ~ 105%. Density 1.5 t/m<sup>3</sup> (2,530 lb/yd<sup>3</sup>).

**Result:** The 2.1 m<sup>3</sup> (2.8 yd<sup>3</sup>) bucket carries 2.2 m<sup>3</sup> (2.9 yd<sup>3</sup>). For optimum stability always consult the bucket selection chart.

Material	Bucket fill, %	Material density		ISO/SAE bucket volume		Actual volume	
		t/m <sup>3</sup>	lb/yd <sup>3</sup>	m <sup>3</sup>	yd <sup>3</sup>	m <sup>3</sup>	yd <sup>3</sup>
Earth/ Clay	~ 110	~ 1.55	~ 2,610	1.9	2.5	2.1	2.8
		~ 1.40	~ 2,360	2.1	2.8	2.3	3.0
		~ 1.30	~ 2,190	2.3	3.0	2.5	3.3
Sand/ Gravel	~ 105	~ 1.65	~ 2,780	1.9	2.5	2.0	2.6
		~ 1.50	~ 2,530	2.1	2.8	2.2	2.9
		~ 1.35	~ 2,280	2.3	3.0	2.1	2.8
Aggre- gate	~ 100	~ 1.75	~ 2,950	1.9	2.5	1.9	2.5
		~ 1.55	~ 2,610	2.1	2.8	2.1	2.8
		~ 1.55	~ 2,610	2.3	3.0	2.3	3.0
Rock	≤100	~ 1.70	~ 2,870	1.7	2.2	1.7	2.2

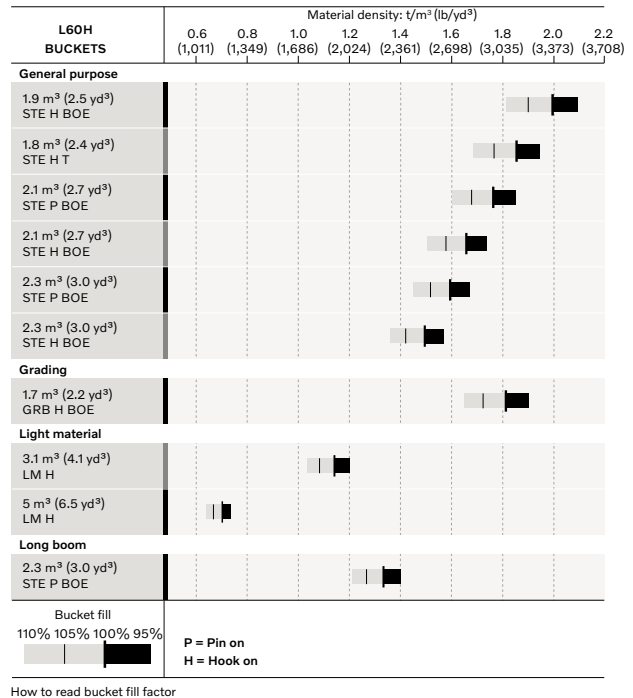

## Supplemental Operating Data

Tires 20.5 R25 L3	Standard boom				Long boom					
	17.5 R25 L3		20.5 R25 L2 *		600/65 R25 L3					
Width over tires	mm	in	-130	-5.1	+10	+0.4	+100	+4	+100	+4.0
Ground clearance	mm	in	-60	-2.4	-10	-0.4	-30	-1.2	-20	-0.8
Tipping load, full turn	kg	lb	-270	-610	+50	+100	-60	-130	-30	-70
Operating weight	kg	lb	-480	-1,060	+90	+200	+10	+20	+10	+20

\* Snow tires



# Equipment

## STANDARD EQUIPMENT

### Engine

Exhaust after-treatment system  
3-stage air cleaner, pre-cleaner, primary and secondary filter  
Indicator glass for coolant level  
Preheating of induction air  
Fuel pre-filter with water trap  
Fuel filter  
Crank case breather oil trap  
Exhaust heat ventilation

### Wheels and tires

20.5R25

### Drivetrain

Automatic Power Shift  
Fully automatic gear shifting, 1-4  
PWM-controlled gear shifting  
Forward and reverse switch by hydraulic lever console  
Rimpull control  
Indicator glass for transmission oil level  
Differentials: Front, 100% hydraulic diff lock. Rear, conventional

### Electrical system

24 V, pre-wired for optional accessories  
Alternator 80A/3135W  
Battery disconnect switch  
Maintenance-free batteries  
Battery box, steel  
Fuel gauge  
Electric horn  
Instrument cluster:  
Fuel level  
Diesel Exhaust Fluid/AdBlue level  
Transmission temperature  
Coolant temperature  
Instrument lighting  
Lighting:  
Twin halogen front headlights with high and low beams  
Parking lights  
Double brake and tail lights  
Turn signals with flashing hazard light function  
Halogen work lights (2 front and 2 rear)  
Co Pilot available  
Rearview camera in Co pilot  
Max Boom height

## STANDARD EQUIPMENT

### Contronic monitoring system

Contronic display  
Fuel consumption  
Diesel Exhaust Fluid/AdBlue consumption  
Ambient temperature  
Clock  
Test function for warning and indicator lights  
Brake test  
Warning and indicator lights:  
Battery charging  
Parking brake  
Warning and display message:  
Regeneration  
Engine coolant temperature  
Charge air temperature  
Engine oil temperature  
Engine oil pressure  
Transmission oil temperature  
Transmission oil pressure  
Hydraulic oil temperature  
Brake pressure  
Parking brake applied  
Brake charging  
Overspeed at direction change  
Axle oil temperature  
Steering pressure  
Crank case pressure  
Attachment lock open  
Level warnings:  
Fuel level  
Diesel Exhaust Fluid/AdBlue level  
Engine coolant level  
Transmission oil level  
Hydraulic oil level  
Washer fluid level  
Engine torque reduction in case of malfunction indication:  
High engine coolant temperature  
High engine oil temperature  
Low engine oil pressure  
High crank case pressure  
High charge air temperature  
Engine shutdown to idle in case of malfunction indication:  
High transmission oil temperature  
Slip in transmission clutches  
Key pad, background lit  
Start interlock when gear is engaged

### Hydraulic system

Main valve, double acting 2-spool with hydraulic pilots  
Variable displacement axial piston pumps (2) for:  
Working hydraulics, pilot hydraulics, steering system, brakes  
Cooling fan, brakes  
Hydraulic control levers  
Mechanical hydraulic lever lock  
Automatic boom kick-out  
Automatic bucket positioner  
Double acting hydraulic cylinders  
Indicator glass for hydraulic oil level  
Hydraulic oil cooler

### Brake system

Dual brake circuits  
Dual brake pedals  
Secondary brake system  
Parking brake, electrical-hydraulic  
Brake wear indicators  
Outboard mounted circulating oil cooled wet disc brakes on all four wheels

# Equipment

## STANDARD EQUIPMENT

### Cab

Volvo Copilot with Rearview camera standard  
 ROPS (ISO 3471), FOPS (ISO 3449)  
 Single key kit door/start  
 Acoustic inner lining  
 Cigarette lighter, 24 V power outlet  
 Lockable door  
 Cab heating with fresh air inlet and defroster  
 Fresh air inlet with two filters  
 Automatic heat control  
 Floor mat  
 Dual interior lights  
 Interior rearview mirrors  
 Dual exterior rearview mirrors  
 Sliding window, right side  
 Tinted safety glass  
 Operator's seat, Comfort ISRI, 2pt seat belt  
 Retractable seatbelt (SAE J386)  
 Adjustable steering wheel  
 Storage compartment  
 Document pocket  
 Sun visor  
 Beverage holder  
 Windshield washer front and rear  
 Windshield wipers front and rear  
 Interval function for front and rear wipers  
 Foot step, left side (toolbox lockable included)  
 ACC control panel, with Fahrenheit scale  
 Anchorage for Operator's manual

### Service and maintenance

Engine oil remote drain and fill  
 Transmission oil remote drain and fill  
 Sliding hydraulic oil cooler and AC-condenser  
 Lubrication manifolds, ground accessible  
 Pressure test ports: transmission and hydraulic, quick connects  
 Service platforms with anti-slip surfaces  
 Quick-fit hydraulic oil fill  
 CareTrack  
 Telematics, 6 -year subscription  
 Toolbox, lockable

### External equipment

Basic fenders, front and rear  
 Viscous cab mounts  
 Rubber engine and transmission mounts  
 Engine hood, electronically openable  
 Frame, joint lock  
 Vandalism lock for engine compartment  
 Lifting eyes  
 Tie down eyes  
 Tow hitch  
 Counterweight, pre-drilled for optional guards

## OPTIONAL EQUIPMENT

### Engine

Air pre-cleaner, cyclone type  
 Air pre-cleaner, oil-bath type  
 Air pre-cleaner, turbo type  
 Engine auto shut down  
 Engine block heater, 120V / 230V  
 Fuel heater  
 Fuel fill strainer  
 Hand throttle control  
 Max. fan speed, hot climate  
 Reversible cooling fan

### Drivetrain

Lock-up torque converter  
 Rear axle with limited slip  
 Speed limiter, 20 km/h  
 Speed limiter, 30 km/h  
 Speed limiter, 40 km/h

## OPTIONAL EQUIPMENT

### Hydraulic system

Arctic kit: Attachment locking, pilot hoses and hydraulic oil  
 Attachment bracket, cast, visibility-optimized  
 Attachment bracket, side-tilting  
 Separate attachment locking, long boom  
 Separate attachment locking, standard boom  
 Single acting lifting function  
 Boom suspension system  
 Hydraulic fluid, biodegradable, Volvo  
 Hydraulic fluid, fire resistant  
 Hydraulic fluid, for hot climate  
 Hydraulic, 2 functions Electro-servo, std/long boom  
 Hydraulic, 3 functions Electro-servo, std/long boom  
 Hydraulic, 4 functions Electro-servo, std/long boom  
 Single lever control, 2 funct Electro-servo, std/long boom  
 Single lever control, 3 funct Electro-servo, std/long boom  
 Single lever control, 4 funct Electro-servo, std/long boom

### Brake system

Parking brake alarm, audible

### Cab

Asbestos dust protection filter  
 Automatic Climate Control, ACC  
 Automatic Climate Control, ACC, corrosion protection condenser  
 Cab air pre-cleaner, cyclone type  
 Carbon filter - cab  
 Remote door opener  
 Lunch box holder  
 Operator's seat, Comfort ISRI, 3pt seat belt  
 Operator's seat, Premium Comfort ISRI  
 Operator's seat, Premium Comfort ISRI 3-point seat belt  
 Armrest, operator's seat, ISRI, left only  
 Safety belt, 3" (75mm) width  
 Safety belt warning  
 Radio installation kit including 12 volt outlet, left-side  
 Radio installation kit including 12 volt outlet, right-side  
 Radio with AUX, Bluetooth and USB connection  
 DAB Radio  
 Subwoofer  
 Forward view mirror  
 Rear view mirrors, el.adjusted and heated  
 Rear view mirrors, long arm right  
 Rear view mirrors, el.adjusted and heated, long arm right  
 Steering wheel knob  
 Sun blinds, rear windows  
 Sun blinds, side windows  
 Timer cab heating  
 Universal door/ignition key  
 Window, sliding, door  
 Cab, Hot applications. Roof, steel  
 Outside steel protection cab  
 Rear view mirrors long arm, cab  
 Reinforced windshield, flat

### Service and maintenance

Automatic lubrication system  
 Automatic lubrication system for long boom  
 Oil sampling valve  
 Refill pump for automatic lubrication system  
 Tool kit  
 Wheel nut wrench kit

---

**OPTIONAL EQUIPMENT**

---

**Electrical**

Battery disconnect switch, additional in cab  
Anti-theft device  
Emergency stop  
License plate holder, lighting  
Reduced function working lights when reverse gear activated  
Side marker lamps  
Forward camera, colour  
Rear view mirrors, long arm, right side  
Rearview mirrors, adjustable, el. heated  
Reverse alarm  
Reverse lights  
Reversing warning light  
Reverse warning light, strobe lightning  
Warning beacon (flasher), LED automatic  
Warning beacon (flasher), LED  
Seatbelt indicator, external  
Working lights, attachments, 1 LED  
Warning beacon LED  
Warning beacon LED automatic  
Halogen Economy package  
Halogen Feature package  
Halogen Power package  
Headlights, assymetric left, halogen  
Working lights, attachments, halogen  
LED Economy package  
LED Feature package  
LED Power package  
LED Intense package  
Can Bus Interface  
Delayed Engine Shutdown

**Protective equipment**

Anti-theft device  
Bellyguard front  
Bellyguard rear  
Boom cylinder hose and tube guards  
Cab roof, heavy duty  
Center hinge and rear frame guard  
Corrosion protection, painting of machine  
Cover plate front frame, heavy-duty  
Cover plate, under cab  
Cover plates rear frame  
Guards for front headlights  
Guards for radiator grill  
Guards for tail lights, heavy-duty  
Wheel/axle seal guards  
Window guards, side and rear  
Windshield guard

---

**OPTIONAL EQUIPMENT**

---

**External equipment**

Deleted front mudguards  
Fire extinguisher  
Bracket for fire extinguisher  
Fire suppression system  
Mudguards, full cover, rear for 80-series tires  
Mudflap kit for mudguards, full cover for 80-series tires  
Mudguards, full cover, rear and front/rear for 65-series tires  
Mudflap kit for mudguards, full cover for 65-series tires  
Footsteps front frame  
Footsteps, right-hand side  
Flexible rear step  
Cab ladder, rubber suspended

**Other equipment**

CareTrack, GSM/Satellite  
CE-marking  
Comfort Drive Control (CDC) Electro-servo  
Secondary steering  
Counterweight, logging  
Counterweight, signal painted, chevrons  
Option for machines without dinitrol  
Noise reduction kit, EU excluding decal  
Sign, 50 km/h  
Sign, slow moving vehicle

**Tires and Rims**

20.5R25  
600/65R25  
620/75R26 Agriculture application only  
750/65R26 Agriculture application only

**Attachments**

Buckets:  
Straight  
Spade nose  
High tipping  
Light material  
Grading  
Wear parts:  
Bolt-on edge  
Bolt-on or weld-on bucket teeth  
Segments  
Log grapples  
Fork equipment  
Material handling arm  
Snow blade  
Broom  
Sand spreading bucket

**V O L V O**