

V O L V O



Volvo Excavators 38.9-40.6 t 313 hp

EC380E

Volvo Construction Equipment



Welcome to our world

Welcome to a world of industry leading machinery. A world where imagination, hard work and technological innovation will lead the way towards developing a future which is cleaner, smarter, and more connected. A world supported by the enduring values of the Volvo Group. A world of stability, sustainability and innovation. A world which we put our customers at the heart of.

Welcome to the world of Volvo Construction Equipment – we think you're going to like it here.

Working harder, working smarter

For over 180 years Volvo has been a pioneer in the design and manufacture of machines which set the standard for efficiency, performance and uptime. Across our range of excavators, wheel loaders and haulers, our reputation for engineering excellence is unrivalled, which means whatever your operation or application, we can provide a total fleet solution to help you succeed.

Building on our proud history, the Volvo Concept Lab continues to create cutting-edge ideas and innovative concepts, to ensure we offer customers machines which work harder and smarter long into the future.



Solutions for you

Our industry leading machines are just the start of your relationship with Volvo. As your partner, we have developed an extensive range of additional solutions to help you improve uptime, boost productivity and reduce costs.

Designed for your business

Structured across nine blocks, our portfolio of products and services are designed to complement your machine's performance and boost your profitability. Simply put, we offer some of the best guarantees, warranties and technological solutions in the industry today.

There when you need us

Whether you're buying new or used, our global network of dealers and technicians offer around-the-clock support, including machine monitoring and world-class parts availability. It's the basis of everything offered by Volvo Services, so you can be confident we've got you covered right from the start.

 Fuel Efficiency Services	 Productivity Services	 Safety Services
 Financial Services	 Uptime Services	 Rental Services
 Volvo Attachments	 Genuine Volvo Parts	 New life Services

BUILDING TOMORROW

Elite efficiency

Fuel efficiency is at the center of the EC380E crawler excavator. With advanced technology including Volvo's unique ECO mode and a new electro-hydraulic control system, this production machine delivers a 9% improvement in fuel efficiency. Experience efficient production at its best with Volvo.

Advanced hydraulics

The new electro-hydraulic system uses intelligent technology to control on-demand flow and reduce internal losses in the hydraulic circuit. This increases controllability, shortens cycle times and improves fuel efficiency – resulting in higher productivity and performance.



Work modes

Volvo's unique, integrated work mode system now includes the G4 mode for optimum fuel efficiency and machine performance. Operators can choose the best work mode for the task at hand – select from I (Idle), F (Fine), G (General), H (Heavy) and P (Power max).



Fuel consumption display

A gauge bar on the monitor measures both instantaneous fuel consumption and average fuel consumption. This allows machine owners and operators to monitor fuel usage on different job sites.



Automatic idling system

Engine speed is reduced to idle when the controls are inactive for a pre-set amount of time (between 3 and 20 seconds). This reduces fuel consumption and noise.

Auto engine shut down

To reduce fuel consumption, the engine will automatically switch off when the machine is inactive for a pre-set amount of time (five minutes is the default setting).



ECO MODE

Volvo's unique ECO mode optimizes the hydraulic system to reduce flow and pressure losses – resulting in improved fuel efficiency without any loss of performance in most operating conditions. ECO mode is automatically selected but can be switched off via the keypad.



HUMAN MACHINE INTERFACE (HMI)

All machine interfaces – including the joysticks, keypad and LCD monitor – are ergonomically positioned and designed for optimum control and efficiency. For operator convenience and ease of use, the number of switches has been significantly reduced.

Boost your productivity

It's a fact that operators work more efficiently when they're given the best tools for the job. That's why, on top of being a superior production machine, the EC380E has an ergonomic design with ideally placed controls and switches. With built in comfort and optimized control, operators will work efficiently and productively all day long.

Keypad

The optimally positioned keypad allows the operator to easily navigate through the LCD monitor and activate machine functions in a safe and comfortable way. The functionality of the camera, air conditioning and lights can be customized via the hot key – enabling the operator to select and save desired configurations.



LCD monitor

The new, color, eight inch LCD monitor displays machine status information including fuel consumption data and service interval alerts – enabling increased uptime and high productivity. The user-friendly design is easy to read in any light conditions.



Shortcut switch

The windshield wipers, camera, audio mute or power max function can be assigned to a shortcut switch located on the joystick. This allows the operator to easily control the selected function by simply pressing a switch.



Seatbelt warning alarm

If the seatbelt is not fastened when the ignition key is turned, a sensor triggers an alarm which sounds for three seconds.

Bluetooth®

For added convenience, operators can now connect a Bluetooth device to the machine.

Non-stop productivity

Experienced and skilled Volvo engineers have developed and rigorously tested Stage V engine systems that deliver the ultimate combination of high productivity and low fuel consumption. Benefit from Volvo's signature high torque at low rpm and experience superior performance and reduced fuel consumption.

Volvo After Treatment System

During the fully automatic regeneration process, particulate matter in the Diesel Particulate Filter is oxidized at low exhaust temperatures via passive regeneration. Volvo uses Selective Catalytic Reduction technology where AdBlue®/Diesel Exhaust Fluid is heated to produce ammonia. This causes a chemical reaction which converts NOx to nitrogen and CO2 – both of which are naturally found in the air. Neither process interrupts machine operation, performance or productivity. ® = registered trademark of the Verband der Automobilindustrie e.V. (VDA)



Diesel-driven heater

The optional diesel-driven coolant heater helps to start the engine in low temperatures while simultaneously heating the cab. The heater can be set in advance to engage at a specific date and time.



Cooling fan

The hydraulically-driven, electronically controlled cooling fan regulates the temperature of the vital components. It automatically activates only when needed – reducing fuel consumption and noise. The optional reversible functionality – which blows air in the opposite direction – enables self-cleaning of the cooling units.





VOLVO ENGINE

Featuring proven, advanced technology and built on decades of experience, Volvo's robust D13 Stage V engine boasts more power while reducing both fuel consumption and emissions and delivering superior quality, reliability and durability.



REINFORCED UNDERCARRIAGE

With a strong three-piece undercarriage and a high strength tensile steel X-shaped frame, Volvo excavators are built to withstand tough conditions. For superior durability, the undercarriage components are reinforced – ensuring long life and high uptime.

Built to last

From quarries to mass excavation, this heavy-duty production machine has been built to work on tough job sites. Featuring a robust, reinforced structure and high quality welding, the EC380E boasts superior strength and durability. Experience reliability you can count on with Volvo.

Superstructure undercover

The heavy-duty superstructure undercover plates increase durability by providing additional protection to the underside of the machine in tough applications – preventing damage from rock and debris.



Doors and hinges

Volvo's durable design features a rigid side door with a robust handle and hinges for superior durability.



Robust design

The reinforced idler frame, track links and bottom rollers are built to withstand tough conditions for improved durability and reliability in demanding applications.



Up your uptime

At Volvo we believe that maintaining your machine should be as quick and easy as possible. That's why our designers and engineers have developed innovative methods to make maintenance easy. With large, wide opening compartment doors and grouped service points, checks will be carried out faster and you'll get the most out of every operating shift.

Service access

Grouped filters are quick and easy to access from ground level. To facilitate fast servicing, grouped greasing points are easily accessed with the machine in one position.



Anti-slip plates

Punched anti-slip plates provide superior grip and increased safety. The design facilitates easy cleaning.



Storage space

A large storage compartment provides a safe and convenient location for items including a toolbox and grease can.



Handrails

Handrails and full size guardrails fold-able provide safe and easy access to the cab and superstructure. The fold-able guardrail is to minimize transportation height when it is folded.



SINGLE MODULE COOLER

The radiator, charged air cooler and hydraulic oil cooler are situated side-by-side on a single layer to maximize efficiency, reduce blockages and aid cleaning. The system is easily accessed from ground level by simply opening the side door.

Quality counts

Safe access

Punched anti-slip plates, handrails and full size fold-able guardrails provide safe and easy access to the machine.

Human Machine Interface (HMI)

All machine interfaces are ergonomically positioned and designed for optimum control and efficiency.

Advanced hydraulics

New electro-hydraulic system and main control valve use intelligent technology to control on-demand flow for high performance and efficiency.

Bucket range

The Volvo quick coupler offers maximum versatility, picking up a wide variety of attachments.

Attachments

Volvo's durable attachments have been purpose-built to deliver maximum productivity and long service life in combination with Volvo machines.

Reinforced undercarriage

The undercarriage components are reinforced to ensure long life, high uptime and ultimate durability in tough conditions.



AdBlue®

Volvo offers a total AdBlue solution that is quality assured, cost efficient and easily accessible. Contact your Volvo dealer for more information. ® = registered trademark of the Verband der Automobilindustrie e.V. (VDA)

LCD monitor

The new, eight inch LCD monitor clearly displays machine status information for easy operation and increased productivity.

ECO mode

Volvo's unique ECO mode improves fuel efficiency without any loss of performance in most operating conditions.

Service access

Grouped filters are quick and easy to access from ground level via large, wide compartment doors.

Volvo engine

Volvo's D13 Stage V engine boasts more power while reducing both fuel consumption and emissions and delivering superior quality, reliability and durability.

Single module cooler

The radiator, charged air cooler and hydraulic oil cooler are situated side-by-side on a single layer to maximize efficiency, reduce blockages and aid cleaning.

Volvo After Treatment System

The automatic regeneration process takes place without interrupting machine operation, performance or productivity.



The perfect match

Maximize your productivity and profitability with the EC380E and Volvo's durable range of attachments. Increase your versatility, access more applications and effectively perform a variety of tasks – all while experiencing faster cycle times and excellent control. Get the most out of your excavator with Volvo.

Bucket range

Volvo's general purpose buckets are the perfect tool for digging and re-handling in soft to medium conditions. Heavy-duty buckets are intended for productive digging in compact materials. Both provide maximum productivity and long life.



Optional auxiliary hydraulics

Factory fitted breaker and shear piping (X1) as well as tilt and rotator piping (X3) increase versatility by enabling a wide range of additional attachments to be used.

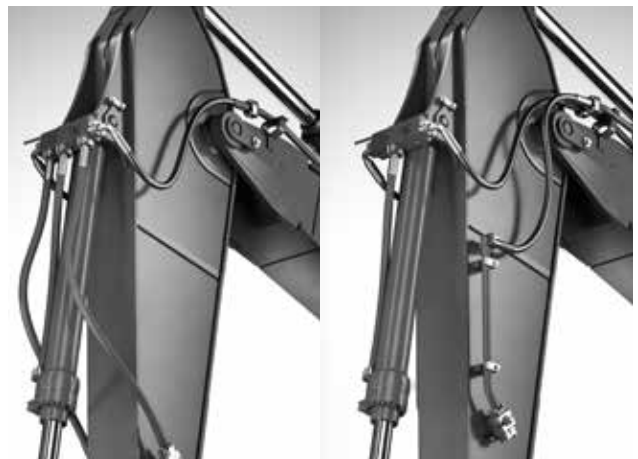

S-type quick coupler

The Volvo S-type quick coupler is designed to work with Volvo attachments – delivering ultimate compatibility and unrivalled performance.



Universal quick coupler

The Volvo universal quick coupler offers maximum versatility. It picks up a variety of attachments from various manufacturers and meets new safety regulations.



Genuine Volvo wear parts

Volvo offers a selection of economic, replaceable wear parts including high quality teeth, segments, side cutters, adapters and shrouds to protect the bucket and ensure long life.



ATTACHMENTS

Volvo's durable attachments have been purposebuilt to work in perfect harmony with Volvo machines, forming one solid, reliable unit. With functions and properties ideally matched, Volvo attachments are an integrated part of the excavator for which they're intended – delivering maximum productivity.

Adding value to your business

Being a Volvo customer means having a complete set of services at your fingertips. Volvo can offer you a long-term partnership, protect your revenue and provide a full range of customer solutions using high quality parts, delivered by passionate people. Volvo is committed to increasing the positive return on your investment and maximising uptime.

Complete Solutions

Volvo has the right solution for you. So why not let us provide all your needs throughout the whole life cycle of your machine? By listening to your requirements, we can reduce your total cost of ownership and increase your revenue.

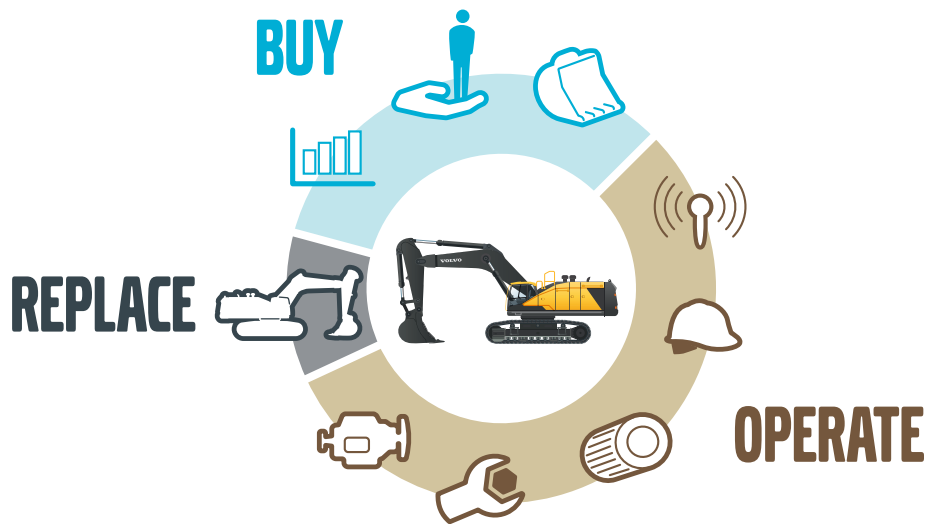

Genuine Volvo Parts

Our attention to detail is what makes us stand out. This proven concept acts as a solid investment in your machine's future. Parts are extensively tested and approved because every part is vital for uptime and performance. Only by using Genuine Volvo Parts, can you be sure that your machine retains the renowned Volvo quality.

Service Network

In order to respond to your needs faster, a Volvo expert is on their way to your job site from one of our Volvo facilities. With our extensive infrastructure of technicians, workshops and dealers, Volvo has a comprehensive network to fully support you using local knowledge and global experience.





CUSTOMER SUPPORT AGREEMENTS

The range of Customer Support Agreements offer preventive maintenance, total repairs and a number of uptime services. Volvo uses the latest technology to monitor machine operation and status, giving you advice to increase your profitability. By having a Customer Support Agreement you are in control of your service costs.

Volvo EC380E in detail

Engine

The latest generation, Volvo engine Stage V emissions certified diesel engine fully meets the demands of the latest, emissions regulations. Featuring Volvo Advanced Combustion Technology (V-ACT), it is designed to deliver superior performance and fuel efficiency. The engine uses precise, highpressure fuel injectors, turbo charger and air-to-air intercooler, and electronic engine controls to optimize machine performance.

Air Filter: 3-stage with precleaner.

Automatic Idling System: Reduces engine speed to idle when the levers and pedals are not activated resulting in less fuel consumption and low cab noise levels.

Engine Stage V	Volvo	D13J
Max power at	r/min	1 700
Net, ISO 9249/SAE J1349	kW	229
	hp	311
Gross, ISO 14396/SAE J1995	kW	230
	hp	313
Max torque	Nm	1 692
at engine speed	r/min	1 275
No. of cylinders		6
Displacement	l	12.8
Bore	mm	131
Stroke	mm	158

Electrical system

High-capacity electrical system that is well protected. Waterproof double-lock harness plugs are used to secure corrosion-free connections. The main relays and solenoid valves are shielded to prevent damage. The master switch is standard. Contronics provides advanced monitoring of machine functions and important diagnostic information.

Voltage	V	24
Batteries	V	2 x 12
Battery capacity	Ah	200
Alternator	V/A	28/80

Swing system

The swing system uses an axial piston motors, driving a planetary gearbox for maximum torque. An automatic holding brake and antirebound valve are standard.

Max. slew speed	r/min	10.2
Max. slew torque	kNm	130.5

Travel System

Each track is powered by an automatic two-speed shift travel motor. The track brakes are multi-disc, spring-applied and hydraulic released. The travel motor, brake and planetary gears are well protected within the track frame.

Max. drawbar pull	kN	276.5
Max. travel speed (low)	km/h	3.4
Max. travel speed (high)	km/h	5.3
Gradeability	°	35

Undercarriage

The undercarriage has a robust X-shaped frame. Greased and sealed track chains are standard.

Track shoes		2 x 50
Link pitch	mm	215.9
Shoe width, triple grouser	mm	600 / 600HD / 700 / 800 / 900
Shoe width, double grouser	mm	600
Bottom rollers		2 x 9
Top rollers		2 x 2

Sound Level

Sound pressure level in cab according to ISO 6396		
L _{pA}	dB	71
External sound level according to ISO 6395 and EU Noise Directive 2000/14/EC		
L _{WA}	dB	105

Hydraulic system

The new electro-hydraulic system and new MCV (main control valve) use intelligent technology to control on-demand flow for highproductivity, high-digging capacity and excellent fuel consumption.

The following important functions are included in the system for optimum performance:

Summation system: Combines the flow of both hydraulic pumps to ensure quick cycle times and high productivity.

Boom priority: Gives priority to the boom operation for faster raising when loading or performing deep excavations.

Arm priority: Gives priority to the arm operation for faster cycle times in leveling and for increased bucket filling when digging.

Swing priority: Gives priority to swing functions for faster simultaneous operations.

Regeneration system: Prevents cavitation and provides flow to other movements during simultaneous operations for maximum productivity.

Power boost: All digging and lifting forces are increased.

Holding valves: Boom and arm holding valves prevent the digging equipment from creeping.

Main pump, Type 2 x variable displacement axial piston pumps

Maximum flow	l/min	2 x 300
--------------	-------	---------

Pilot pump, Type Gear pump

Maximum flow	l/min	32.6
--------------	-------	------

Implement	MPa	32.4/35.3
-----------	-----	-----------

Travel circuit	MPa	35.3
----------------	-----	------

Slew circuit	MPa	27.9
--------------	-----	------

Pilot circuit	MPa	3.9
---------------	-----	-----

Hydraulic Motors

Travel: Variable displacement axial piston motor with mechanical brake.

Slew: Fixed displacement axial piston motor with mechanical brake

Hydraulic Cylinders

Mono boom		2
Bore x Stroke	ø x mm	160 x 1 530
Arm		1
Bore x Stroke	ø x mm	175 x 1 700
Bucket		1
Bore x Stroke	ø x mm	145 x 1 285
ME Bucket		1
Bore x Stroke	ø x mm	160 x 1 250
Bucket for LR boom		1
Bore x Stroke	ø x mm	140 x 1 140

Service Refill

Fuel tank	l	620
DEF/AdBlue® tank	l	62.5
Hydraulic system, total	l	500
Hydraulic tank	l	225
Engine oil	l	42
Engine coolant	l	60
Slew reduction unit	l	6.5
Travel reduction unit	l	2 x 6.8

Cab

The operator's cab has easy access via a wide door opening. The cab is supported on hydraulic dampening mounts to reduce shock and vibration levels. These along with sound absorbing lining provide low noise levels. The cab has excellent all-round visibility. The front windshield can easily slide up into the ceiling, and the lower front glass can be removed and stored in the side door.

Integrated airconditioning and heating system: The pressurized and filtered cab air is supplied by an automatically controlled fan. The air is distributed throughout the cab from 14 vents.

Ergonomic operator's seat: The adjustable seat and joystick console move independently to accommodate the operator. The seat has 12 different adjustments plus a seat belt for the operator's comfort and safety.

Refrigerant of the type R134a is used when this machine is equipped with air conditioning. Contains fluorinated greenhouse gas R134a, Global Warming Potential 1430 CO₂-eq.

Specifications

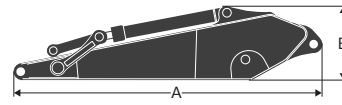
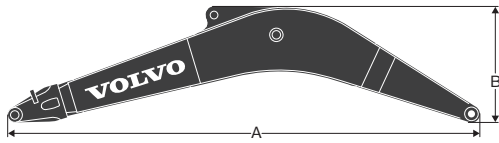

DIMENSIONS

Boom				Arm				
Boom	Unit	mono	mono	Description	Unit	2.6	3.2 HD	3.9
	m	6.2 ME	6.45 HD	Arm	m			
A	mm	6 460	6 700	A	mm	3 780	4 360	5 080
B	mm	1 740	1 800	B	mm	1 145	1 145	1 145
Width	mm	820	820	Width	mm	560	560	560
Weight	kg	3 355	3 310	Weight	kg	2 050	2 180	2 300

* Includes arm cylinder, piping and pin

* Includes bucket cylinder, linkage and pin

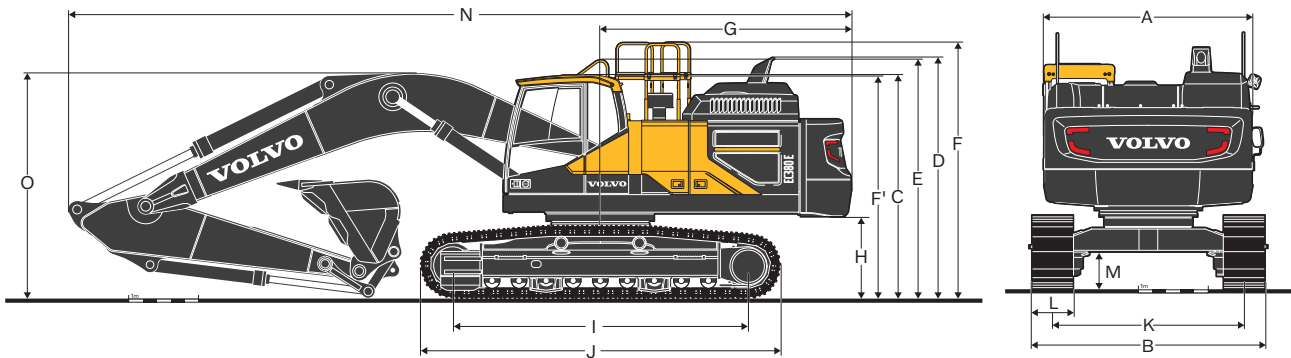

DIMENSIONS

Description	Unit	EC380EL				EC380ENL			
		6.2	6.45	6.45	3.9	6.2	6.45	6.45	3.9
Boom	m	6.2	6.45	6.45	3.9	6.2	6.45	6.45	3.9
Arm	m	2.6	2.6	3.2	3.9	2.6	2.6	3.2	3.9
A. Overall width of upper structure	mm	2 990	2 990	2 990	2 990	2 990	2 990	2 990	2 990
B. Overall width	mm	3 340	3 340	3 340	3 340	2 990	2 990	2 990	2 990
C. Overall height of cab	mm	3 220	3 220	3 220	3 220	3 220	3 220	3 220	3 220
D. Overall height of diffuser	mm	3 465	3 465	3 465	3 465	3 465	3 465	3 465	3 465
E. Overall height of handrail	mm	3 440	3 440	3 440	3 440	3 440	3 440	3 440	3 440
F. Overall height of guardrail (unfolded)	mm	3 685	3 685	3 685	3 685	3 685	3 685	3 685	3 685
F'. Overall height of guardrail (folded)	mm	3 215	3 215	3 215	3 215	3 215	3 215	3 215	3 215
G. Tail swing radius	mm	3 600	3 600	3 600	3 600	3 600	3 600	3 600	3 600
H. Counterweight clearance *	mm	1 150	1 150	1 150	1 150	1 150	1 150	1 150	1 150
I. Tumbler length	mm	4 240	4 240	4 240	4 240	4 240	4 240	4 240	4 240
J. Track length	mm	5 180	5 180	5 180	5 180	5 180	5 180	5 180	5 180
K. Track gauge	mm	2 740	2 740	2 740	2 740	2 390	2 390	2 390	2 390
L. Shoe width	mm	600	600	600	600	600	600	600	600
M. Min. ground clearance *	mm	500	500	500	500	500	500	500	500
N. Overall length	mm	11 060	11 310	11 220	11 270	11 060	11 310	11 220	11 270
O. Overall height of boom	mm	3 610	3 580	3 360	3 605	3 610	3 580	3 360	3 605

* Without shoe grouser

Specifications

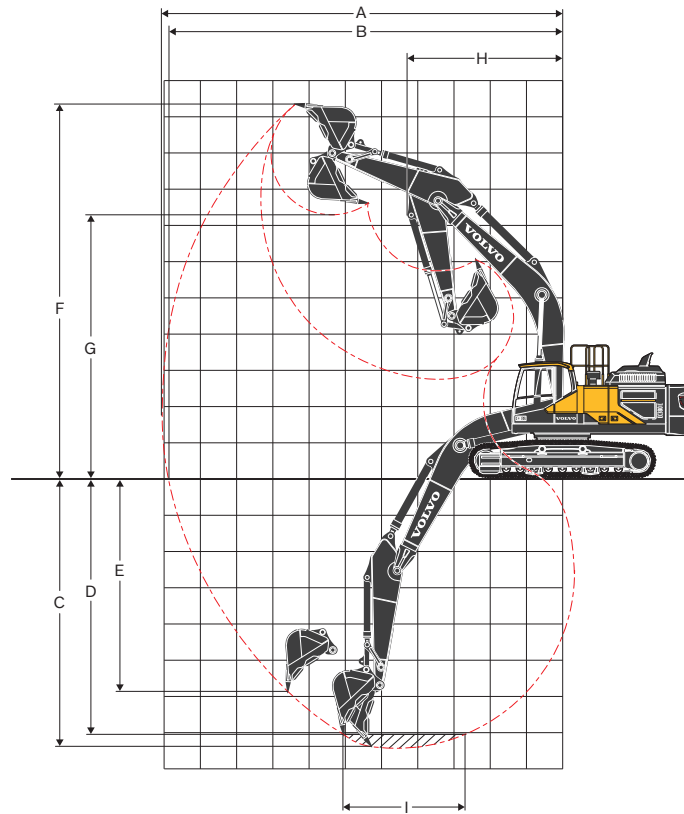

WORKING RANGE

Description	Unit	EC380E			
Boom	m	6.2	6.45		
Arm	m	2.6	2.6	3.2	3.9
A. Max. digging reach	mm	10 450	10 695	11 220	11 855
B. Max. digging reach on ground	mm	10 225	10 480	11 010	11 665
C. Max. digging depth	mm	6 755	6 990	7 590	8 290
D. Max. digging depth (2.44 m level)	mm	6 575	6 805	7 425	8 145
E. Max. vertical wall digging depth	mm	4 860	5 000	5 510	6 110
F. Max. cutting height	mm	10 055	10 195	10 370	10 640
G. Max. dumping height	mm	6 800	6 950	7 140	7 415
H. Min. front slew radius	mm	4 090	4 290	4 280	4 305

Digging forces with direct fit bucket

Breakout force - bucket (Normal/Power boost)	SAE J1179	kN	214.5	198.0	198.0	198.0
	SAE J1179	kN	234.5	215.0	215.0	215.0
	ISO 6015	kN	243.4	221.7	221.7	221.7
	ISO 6015	kN	265.4	242.7	242.7	242.7
Tearout force - dipper arm (Normal/Power boost)	SAE J1179	kN	187.7	195.9	161.9	141.3
	SAE J1179	kN	205.7	212.9	176.9	154.3
	ISO 6015	kN	193.9	201.1	166.0	144.4
	ISO 6015	kN	211.9	219.1	181.0	157.4

MACHINE WEIGHTS AND GROUND PRESSURE

Description	Shoe width	Operating weight	Ground pressure	Operating weight	Ground pressure
	mm	kg	kPa	kg	kPa
Triple grouser	600	39 245	71.6	38 865	70.9
	700	39 690	62.0	39 305	61.4
	800	40 140	54.9	39 755	54.4
	900	40 585	49.3	40 200	48.9
Triple grouser(HD)	600	39 675	72.4	39 290	71.7
Double grouser	600	39 525	72.1	39 140	71.4

EC380E with LC undercarriage, 6.45 m boom, 3.2 m arm, 1 574 kg bucket, 6 700 kg counterweight

 EC380E with NLC undercarriage, 6.45 m boom, 3.2 m arm, 1 574 kg bucket, 6 700 kg counterweight

BUCKET SELECTION GUIDE

Bucket type		Capacity	Cutting width	Weight	Teeth	EC380ENL				EC380EL							
						600 mm shoe, 6 700 kg counterweight								600 mm shoe, 6 700 kg counterweight			
						L	mm	kg	EA	6.2 m Boom	6.45 m Boom			6.2 m Boom	6.45 m Boom		
										2.6 m	2.6 m	3.2 m	3.9 m	2.6 m	2.6 m	3.2 m	3.9 m
Direct fit Buckets	General purpose	870	750	1176	3	C	C	C	C	C	C	C	C	C			
		1000	900	1271	4	C	C	C	C	C	C	C	C	C			
		1420	1200	1514	5	C	C	C	C	C	C	C	C	C			
		1670	1350	1629	5	C	C	C	C	C	C	C	C	C			
		1920	1500	1769	5	C	C	C	C	C	C	C	C	C			
	2330	1750	1986	5	C	C	C	B	C	C	C	C	B				
	Heavy duty	1000	900	1425	4	D	D	D	D	D	D	D	D	D			
		1420	1200	1699	5	D	D	D	D	D	D	D	D	D			
		1920	1500	1970	5	D	D	D	C	D	D	D	D	C			
		2330	1750	2175	5	D	D	C	B	D	D	C	C	B			
870		750	1176	3	C	C	C	C	C	C	C	C	C				
Direct fit Buckets (UQC interface)	General purpose	1000	900	1271	4	C	C	C	C	C	C	C	C				
		1420	1200	1514	5	C	C	C	C	C	C	C	C				
		1670	1350	1629	5	C	C	C	C	C	C	C	C				
		1920	1500	1769	5	C	C	C	B	C	C	C	C				
		2330	1750	1967	5	C	C	B	A	C	C	B	A				
	Heavy duty	1000	900	1425	4	D	D	D	D	D	D	D	D				
		1420	1200	1699	5	D	D	D	D	D	D	D	D				
		1920	1500	1970	5	D	D	D	B	D	D	D	B				
		2330	1750	2175	5	B	A	X	X	B	B	A	X				
		1000	900	1239	4	C	C	C	C	C	C	C	C				
Quick coupler Buckets (S3 Quick coupler)	General purpose	1420	1200	1482	5	C	C	C	C	C	C	C	C				
		1670	1350	1597	5	C	C	C	C	C	C	C	C				
		1920	1500	1720	5	C	C	C	B	C	C	C	C				
		2330	1750	1911	5	C	C	C	A	C	C	C	B				
		1000	900	1393	4	D	D	D	D	D	D	D	D				
	Heavy duty	1420	1200	1648	5	D	D	D	D	D	D	D	D				
		1670	1350	1791	5	D	D	D	C	D	D	D	D				
		1920	1500	1921	5	D	D	C	B	D	D	D	B				
		2330	1750	2119	5	C	C	B	A	C	C	B	A				

Please consult with your Volvo dealer for the proper match of buckets and attachments to suit the application. The recommendations are given as a guide only, based on typical operation conditions. Bucket capacity based on ISO 7451, heaped material with a 1:1 angle of repose.

X : Not recommended
Maximum material density
 A 1 200 - 1 300 kg/m³ Coal, Caliche, Shale
 B 1 400 - 1 600 kg/m³ Wet earth and clay, Limestone, Sandstone
 C 1 700 - 1 800 kg/m³ Granite, Wet sand, Well blasted rock
 D > 1 900 kg/m³ Wet mud, Iron ore

LIFTING CAPACITY EC380EL

Lifting capacity at the arm end without bucket.

For lifting capacity including bucket, simply subtract actual weight of the direct fit bucket or the bucket with quick coupler from the following values.

	Lifting hook related to ground level	1.5 m		3.0 m		4.5 m		6.0 m		7.5 m		9.0 m		Max. reach		m		
		Along UC	Across UC	Along UC	Across UC	Along UC	Across UC	Along UC	Across UC	Along UC	Across UC	Along UC	Across UC	Along UC	Across UC			
Boom : 6.45m Arm : 3.9m Shoe : 600mm CWT : 7 250kg	9 m	kg													*6 920	*6 920	7.2	
	7.5 m	kg								*8 160	*8 160				*6 470	*6 470	8.4	
	6 m	kg								*8 510	*8 510	*7 680	6 640		*6 310	*6 310	9.2	
	4.5 m	kg						*10 380	*10 380	*9 380	8 740	*8 850	6 530		*6 370	5 720	9.7	
	3 m	kg				*16 410	*16 410	*12 460	11 710	*10 510	8 400	*9 430	6 360		*6 600	5 380	10.0	
	1.5 m	kg				*20 040	16 850	*14 440	11 090	*11 650	8 060	9 540	6 170		*7 040	5 260	10.0	
	0 m	kg			*9 320	*9 320	*22 030	16 170	*15 870	10 650	12 290	7 790	9 370	6 020		*7 760	5 350	9.8
	-1.5 m	kg	*9 510	*9 510	*14 220	*14 220	*22 500	15 930	*16 510	10 420	12 120	7 640	9 300	5 960		8 850	5 680	9.3
	-3 m	kg	*14 830	*14 830	*20 550	*20 550	*21 740	15 960	*16 250	10 390	12 100	7 620				9 990	6 390	8.6
	-4.5 m	kg	*21 190	*21 190	*27 500	*27 500	*19 600	16 220	*14 770	10 550						*11 110	7 850	7.5
-6 m	kg			*20 790	*20 790	*15 130	15 130								*11 300	*11 300	5.8	

Notes: 1. Machine in "Fine Mode-F" (Power Boost) for lifting capacities. 2. The above loads are in compliance with SAE J1097 and ISO 10567 Hydraulic Excavator Lifting Capacity Standards. 3. Rated loads do not exceed 87% of hydraulic lifting capacity or 75% of tipping load. 4. Rated loads marked with an asterisk (*) are limited by hydraulic capacity rather than tipping load.

LIFTING CAPACITY EC380ENL

Lifting capacity at the arm end without bucket.

For lifting capacity including bucket, simply subtract actual weight of the direct fit bucket or the bucket with quick coupler from the following values.

	Lifting hook related to ground level	1.5 m		3.0 m		4.5 m		6.0 m		7.5 m		9.0 m		Max. reach		m		
		Along UC	Across UC	Along UC	Across UC	Along UC	Across UC	Along UC	Across UC	Along UC	Across UC	Along UC	Across UC	Along UC	Across UC			
Boom : 6.2m Arm : 2.6m Shoe : 600mm CWT : 7 250kg	7.5 m	kg						*10 730	*10 730						*10 900	9 180	6.7	
	6 m	kg						*11 250	10 850	*10 770	7 580				*10 800	7 280	7.7	
	4.5 m	kg				*15 890	*15 890	*12 700	10 400	*11 230	7 430				*10 900	6 350	8.3	
	3 m	kg				*19 810	14 740	*14 500	9 870	*12 070	7 180				10 320	5 880	8.6	
	1.5 m	kg				*22 330	13 960	*16 020	9 430	12 420	6 950				10 150	5 750	8.6	
	0 m	kg				*22 870	13 710	*16 800	9 170	12 250	6 800				10 520	5 910	8.4	
	-1.5 m	kg			*17 780	*17 780	*22 050	13 730	*16 610	9 120	12 240	6 790				11 600	6 480	7.8
	-3 m	kg			*26 540	*26 540	*19 900	13 950	*15 090	9 250						*12 560	7 760	6.9
-4.5 m	kg					*15 360	14 450								*12 310	11 140	5.4	
Boom : 6.45m Arm : 2.6m Shoe : 600mm CWT : 7 250kg	7.5 m	kg						*11 020	10 810	*10 360	7 600				*10 420	8 530	7.0	
	6 m	kg						*12 580	10 320	*10 970	7 400				*10 360	6 880	8.0	
	4.5 m	kg				*16 080	15 750	*12 580	10 320	*10 970	7 400				*10 480	6 030	8.5	
	3 m	kg						*14 430	9 760	*11 870	7 130				9 850	5 610	8.8	
	1.5 m	kg						*15 940	9 320	12 360	6 890				9 690	5 480	8.8	
	0 m	kg				*21 850	13 560	*16 690	9 070	12 180	6 730				10 010	5 620	8.6	
	-1.5 m	kg			*14 880	*14 880	*21 890	13 610	*16 550	9 020	12 140	6 700				10 970	6 120	8.1
	-3 m	kg			*26 310	*26 310	*19 940	13 820	*15 270	9 140						*12 160	7 240	7.2
-4.5 m	kg			*20 930	*20 930	*16 070	14 270								*12 110	9 990	5.8	
Boom : 6.45m Arm : 3.2m Shoe : 600mm CWT : 7 250kg	7.5 m	kg								*9 370	7 800				*8 200	7 510	7.7	
	6 m	kg								*9 500	7 730				*7 980	6 220	8.5	
	4.5 m	kg				*14 350	*14 350	*11 610	10 510	*10 260	7 500	*8 790	5 590		*8 060	5 520	9.1	
	3 m	kg				*18 440	14 900	*13 580	9 920	*11 290	7 200	9 580	5 460		*8 390	5 150	9.3	
	1.5 m	kg				*21 460	13 950	*15 330	9 410	*12 280	6 910	9 420	5 330		8 890	5 030	9.4	
	0 m	kg				*22 610	13 550	*16 410	9 080	12 170	6 710	9 320	5 230		9 130	5 130	9.1	
	-1.5 m	kg			*15 110	*15 110	*22 370	13 480	*16 640	8 950	12 070	6 620				9 870	5 510	8.6
	-3 m	kg	*17 590	*17 590	*23 840	*23 840	*20 970	13 620	*15 880	9 000	12 140	6 690				11 440	6 350	7.8
-4.5 m	kg			*24 300	*24 300	*17 980	13 970	*13 490	9 260						*11 830	8 230	6.6	
Boom : 6.45m Arm : 3.9m Shoe : 600mm CWT : 7 250kg	9 m	kg													*6 920	*6 920	7.2	
	7.5 m	kg								*8 160	8 010				*6 470	*6 470	8.4	
	6 m	kg								*8 510	7 880	*7 680	5 780		*6 310	5 520	9.2	
	4.5 m	kg						*10 380	*10 380	*9 380	7 610	*8 850	5 670		*6 370	4 950	9.7	
	3 m	kg				*16 410	15 380	*12 460	10 110	*10 510	7 280	*9 430	5 500		*6 600	4 640	10.0	
	1.5 m	kg				*20 040	14 220	*14 440	9 510	*11 650	6 950	9 430	5 320		*7 040	4 530	10.0	
	0 m	kg			*9 320	*9 320	*22 030	13 580	*15 870	9 090	12 160	6 690	9 270	5 180		*7 760	4 600	9.8
	-1.5 m	kg	*9 510	*9 510	*14 220	*14 220	*22 500	13 350	*16 510	8 870	11 980	6 540	9 200	5 110		8 750	4 880	9.3
	-3 m	kg	*14 830	*14 830	*20 550	*20 550	*21 740	13 380	*16 250	8 840	11 970	6 520				9 880	5 480	8.6
	-4.5 m	kg	*21 190	*21 190	*27 500	26 760	*19 600	13 630	*14 770	8 990						*11 110	6 740	7.5
-6 m	kg			*20 790	*20 790	*15 130	14 160								*11 300	9 990	5.8	

Notes: 1. Machine in "Fine Mode-F" (Power Boost) for lifting capacities. 2. The above loads are in compliance with SAE J1097 and ISO 10567 Hydraulic Excavator Lifting Capacity Standards. 3. Rated loads do not exceed 87% of hydraulic lifting capacity or 75% of tipping load. 4. Rated loads marked with an asterisk (*) are limited by hydraulic capacity rather than tipping load.

Equipment

STANDARD EQUIPMENT

Engine

Turbocharged, 4 stroke diesel engine with water cooling, direct injection and charged air cooler that meets EU Stage V requirements

Air filter with indicator

Air intake heater

Cyclone pre-cleaner

Electric engine shut-off

Fuel filter and water separator

Fuel filler pump: 50 l/min, with automatic shut-off

Alternator, 80 A

Electric / Electronic control system

Contronics

Advanced mode control system

Self-diagnostic system

Machine status indication

Engine speed sensing power control

Automatic idling system

One-touch power boost

Safety stop/start function

Adjustable 8inch LCD color monitor

Master electrical disconnect switch

Engine restart prevention circuit

High-capacity halogen lights:

Frame-mounted 2

Boom-mounted 2

Batteries, 2 x 12 V / 200 Ah

Start motor, 24 V / 7 kW

Frame

Access way with handrail

Tool storage area

Punched metal anti-slip plates

Undercover (heavy-duty)

Undercarriage

Undercover (heavy-duty)

Hydraulic track adjusters

Greased and sealed track link

Track Guard

Hydraulic system

Hose rupture valve: boom

Overload warning device

Automatic sensing hydraulic system

2-pump flow bucket circuit

Summation system

Boom priority

Arm priority

Swing priority

Boom, arm and bucket regeneration valves

Swing anti-rebound valves

Boom and arm holding valves

Multi-stage filtering system

Cylinder cushioning

Cylinder contamination seals

Auxiliary hydraulic valve

Automatic two-speed travel motors

Hydraulic oil, ISO VG 46

STANDARD EQUIPMENT

Cab and interior

ROPS (ISO12117-2) certified cab

Silicon oil and rubber mounts with spring

Travel pedals and hand levers

Adjustable operator seat and joystick control console

Control joysticks with 4 switches each

Heater & air-conditioner, automatic

Flexible antenna

AM/FM stereo with MP3, USB and bluetooth input

Hydraulic safety lock lever

Cab, all-weather sound suppressed, includes:

Cup holders

Door locks

Tinted glass

Floor mat

Horn

Large storage area

Pull-up type front window

Removable lower windshield

Seat belt

Safety glass

Sun screens, front, roof, rear

Rain shield

Windshield wiper with intermittent feature

Rear view camera

Master key

Track shoes

600 mm with triple grousers

Digging Equipment

Boom: 6.45 m HD

Arm: 3.2 m HD

Manual centralized lubrication

OPTIONAL EQUIPMENT

Engine

Block heater: 120 V, 240 V

Oil bath pre-cleaner

Diesel coolant heater, 10 kW

Water separator with heater

Auto engine shutdown

Electric

Extra work lights: Halogen/LED

Cab-mounted 3

Boom-mounted 2

Counterweight-mounted 1

Travel alarm

Anti-theft system

Rotating warning beacon

Undercarriage

Full track guard

OPTIONAL EQUIPMENT

Hydraulic system

Hose rupture valve: arm
Boom float function
Hydraulic piping:
Work tool management system (up to 20 programmable memories)
Hammer & shear, 1 and 2 pump flow
Hammer & shear:
variable flow and pressure pre-setting
Additional return filter
Slope & rotator
Grapple
Oil leak (drain) line
Quick coupler piping
Volvo hydraulic quick coupler S3
Volvo hydraulic quick coupler VQC-HU
Volvo hydraulic quick coupler DR38
Hydraulic oil, ISO VG 32
Hydraulic oil, ISO VG 46
Hydraulic oil, ISO VG 68
Hydraulic oil, biodegradable 46
Hydraulic oil, longlife oil 32
Hydraulic oil, longlife oil 46
Hydraulic oil, longlife oil 68

Counterweight

6 200 kg, 6 700 kg, 7 250 kg

OPTIONAL EQUIPMENT

Cab and interior

Fabric seat with heater
Fabric seat with heater and air suspension
Pilot control pattern change
Opening top hatch
Falling object guard (FOG)
Frame-mounted
Cab-mounted
Cab-mounted falling object protective structure (FOPS)
Smoker kit (ashtray and lighter)
Safety net for front window
Lower wiper with intermittent control
Anti-vandalism kit
Specific key

Track shoes

Track shoes 600/700/800/900 mm with triple grousers
Track shoes 600 mm HD with triple grousers and HD links
Track shoes 600 mm with double grousers

Digging Equipment

Boom: 6.2 m ME
Arm: 2.6 m ME, 3.9 m HD
Linkage with lifting eye

Service

Tool kit, daily maintenance
Tool kit, full scale
Automatic lubrication system
Air compressor

SELECTION OF VOLVO OPTIONAL EQUIPMENT

Auxiliary hydraulics,
(Breaker / Shear, Tilt / Rotator)

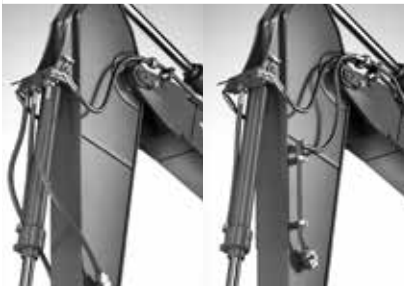

Side-view camera



LED Lights



Air compressor



Mass excavation

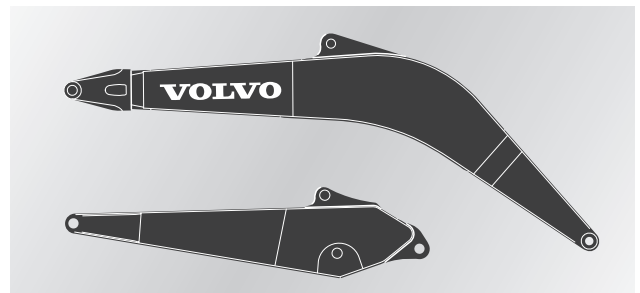

Not all products are available in all markets. Under our policy of continuous improvement, we reserve the right to change specifications and design without prior notice. The illustrations do not necessarily show the standard version of the machine.

V O L V O