



Volvo Wheel Loaders 8.6-9.9 t / 19,114-21,958 lb 98-117 hp

L45H

Volvo Construction Equipment

L45H



Small size: big talent



Take control

- Comfort Drive Control: lever steering (optional)
- Inch-brake pedal
- Joystick or multi-lever hydraulic pilot control



Comfortable cab

- Easy cab access
- All-around visibility
- Intuitive controls
- Quiet, steady environment



Short cycle times

- Differential lock front and rear
- Load-sensing hydraulics
- Powerful, fuel efficient Volvo engine
- Torque parallel linkage



High-speed hydrostatic transmission

- Travel up to 31mph (50km/h)
- Drive mode selector
- Adjustable tractive power
- Hand speed limiter (optional)



Maximum uptime

- Reversible cooling fan
- Maintenance-free rear axle oscillation
- Dual element air filter protecting the engine
- Grouped grease points
- DPF regeneration occurs every 500 hours



The complete package

- Range of matched Volvo Attachments
- CareTrack telematics system: easy machine monitoring
- Genuine Volvo Parts
- Maintenance and Repair agreements

Balanced and compact design



- Long wheel base, low center of gravity
- Transversal engine mounting: optimal weight distribution
- Sloped counterweight enables high departure angles

Volvo L45H in detail

Engine

Volvo Tier 4f compliant, 4 liter, 4-cylinder in-line turbocharged diesel engine; featuring common rail fuel injection system and externally cooled exhaust gas recirculation (EGR). Exhaust aftertreatment system includes a diesel oxidation catalyst (DOC), a diesel particulate filter (DPF) and a selective catalytic reduction (SCR).

Cooling pack includes side by side arranged radiators for engine coolant, hydraulic oil and charge air cooler.

Engine	Volvo	D4J
Max power at	r/min (r/s)	1 800 - 2 200 (30 - 36,7)
SAE J1995 gross	kW (hp)	75 (100)
SAE J1349, ISO 9249 net	kW (hp)	73 (97.9)
Max. torque at	r/min (r/s)	1,450 (24.2)
SAE J1995 gross	Nm (ft lbf)	425 (314)
SAE J1349, ISO 9249 net	Nm (ft lbf)	416 (307)
Economic working range	r/min (r/s)	1 200 - 1 800 (20 - 30)
Displacement	l (in ³)	4 (244)

Electrical System

Contronic electrical system with central warning light and buzzer, providing clear and easy to read information to the operator.

LCD display with main and sub information field, adjustable to various languages. Display information in three categories:

- Information on continuous operating data,
- Check requests (based on vehicle and error messages)
- Warning (with alarm texts).

Additional audible warning by a buzzer.

Indicator and activation lights for various control and monitoring functions. Gauges for Adblue® level, fuel tank level, speedometer, engine speed, coolant temperature, transmission/hydraulic oil temperature.

A keypad allows easy navigation on the central instrument display.

Direct access buttons for Engine, Transmission, Hydraulics, Axles & Brakes, Electrical system, Vehicle information, Vehicle messages, Service, Settings and Cycle information.

Voltage	V	24
Batteries	V	2x12
Battery capacity	Ah	2x100
Cold cranking capacity, approx	A	830
Alternator rating	W/A	3 080 / 110
Starter motor output	kW	5.5

Drivetrain

Hydrostatic transmission allows for of speed range change without any tractive power interruption.

Maximum tractive power is available in all speed ranges, regardless of the driving direction.

Automatic power regulation prevents engine stalling in case of additional power demand from the working hydraulics or the auxiliaries, and protects from overheating in case of overload.

Fully floating axle shafts with planetary hub reductions and steel casted axle housing.

Fixed front axle and oscillating rear axle, both self-lubricated.

100% differential lock on both axles.

For 40/50 km/h* speed version only: The drive modes selector enable to select the best possible driveline setting for every applications and operator preference.

*max vehicle speed market dependent

Travel speed, forward/reverse

20 km/h (12.4 mi/h)-speed version		
1st gear	km/h (mi/h)	0 - 6 (0 - 3.7)
2nd gear	km/h (mi/h)	0 - 20 (0 - 12.4)
30 km/h (19 mi/h)-speed version		
1st gear	km/h (mi/h)	0 - 6 (0 - 3.7)
2nd gear	km/h (mi/h)	0 - 30 (0 - 19)
45 km/h (28 mi/h)*-speed version		
1st gear	km/h (mi/h)	0 - 6 (0 - 3.7)
2nd gear	km/h (mi/h)	0 - 19 (0 - 11.8)
3rd gear	km/h (mi/h)	0-45* (0-28*)

*max vehicle speed market dependent

Linkage

Double acting cylinder for all functions		
Linkage system	Torque parallel (TP)	
Lift cylinders	2	
Tilt cylinders	1	
Lift time (loaded)	s	4.8
Lowering time (empty)	s	3.2
Dump time	s	1.5

Brake system

Brake system 20 & 30 km/h (12.4 & 19 mi/h) speed version:

The brake system complies with ISO 3450 requirements. Single circuit service brake featuring hydraulically operated wet disk brakes on rear axle.

An Inching-brake pedal provides hydrostatic wearless braking in the first stage for precise approach; if applied further the service brakes takes over for final braking and machine immobilization.

Parking brake: Mechanically operated dry disc brake located on the input shaft of the front axle.

Brake system 40/50 km/h (24.8/31 mi/h)*:

The brake system complies with ISO 3450 requirements. Dual circuit service brake featuring hydraulically operated wet disk brakes on front and rear axle.

An electronically Inching-brake pedal provides hydrostatic wearless braking in the first stage for precise approach; if applied further the service brakes takes over for final braking and machine immobilization.

Parking brake: Mechanically operated dry disc brake located on the input shaft of the front axle.

* max vehicle market dependent

Steering System

Load sensing hydrostatic articulated steering with double acting cylinders.

System supply: The steering system has priority feed from the load-sensing axial piston pump with variable displacement.

Steering cylinders: Two double-acting cylinders. Elastical end-stops.

Steering cylinders	2	
Working pressure	MPa (psi)	17.5 (2,538)
Maximum flow	l/min (gal/min)	70 (18.5)
Max articulation	± °	40

Cab

The cab is tested and approved according to ROPS (ISO 3471, SAE J1040) and FOPS (ISO 3449).

The cab is compliant with ISO 6055 requirements regarding Operator overhead protection - Industrial trucks and SAE J386 regarding Operator Restraint System.

The operator's seat features an adjustable suspension and a retractable seatbelt. Fresh air is filtered through two large elements prior entering, ensuring extremely clean air distribution in the cab.

11 air flow settings or an automatic mode provides efficient ventilation. Air vents are available to all windows enabling fast de-misting and defrosting. The conronic monitoring system provides all important information in a central position and all machine controls are located in the operator's field of vision.

Sound Level

Sound pressure level in cab according to ISO 6396

L _{pA}	dB	70
L _{pA} (as option)	dB	68

External sound level according to ISO 6395 and EU Noise Directive 2000/14/EC

L _{WA}	dB	102
-----------------	----	-----

Service Refill

Fuel tank	l (gal)	160 (42.3)
DEF/AdBlue® tank	l (gal)	20 (5.3)
Engine oil	l (gal)	14 (3.7)
Engine coolant	l (gal)	20 (5.3)
Hydraulic tank	l (gal)	95 (25.1)

Front axle oil

20/30 km/h (12.4/18.6 mi/h) speed version	l (gal)	17.5 (4.6)
---	---------	------------

Rear axle oil

20/30 km/h (12.4/18.6 mi/h) speed version	l (gal)	17.5 (4.6)
---	---------	------------

Front axle oil

40/50 km/h* (24.8/31 mi/h)* speed version	l (gal)	17 (4.5)
---	---------	----------

Rear axle oil

40/50 km/h* (24.8/31 mi/h)* speed version	l (gal)	18.3 (4.8)
---	---------	------------

Transmission oil

40/50 km/h* (24.8/31 mi/h)* speed version	l (gal)	2.7 (0.71)
---	---------	------------

*max vehicle speed market dependent

Hydraulic system

Closed center load sensing hydraulic system with pilot operated control valves.

System supply:

A variable displacement piston pump provides flow to the working hydraulic and steering system. The steering function has always priority. A gear pump provides flow to the braking system and the cooling fan.

System control:

Double-acting 3-spools main control valve (4-spools valve as option).

The lift function has four positions: lift, hold (neutral), lower and float position.

An optional automatic boom kick-out can be switched on and off and is adjustable to any position between maximum reach and full lifting height.

The tilt function has three positions: rollback, hold (neutral) and dump.

The standard bucket positioner system allows to easily adjust the tilt angle to a predefined position.

A third and fourth hydraulic functions are available as options to power hydraulic implements (Volvo hydraulic Attachment Bracket, Hi-Tip bucket, angle sweeper etc...)

Filtration:

Full-flow filtration through 10 micron (absolute) filter cartridge in a combined suction-return-filter.

Cooling:

Thermostatically controlled oil flow to oil cooler (fast warm-up, optimized cooling).





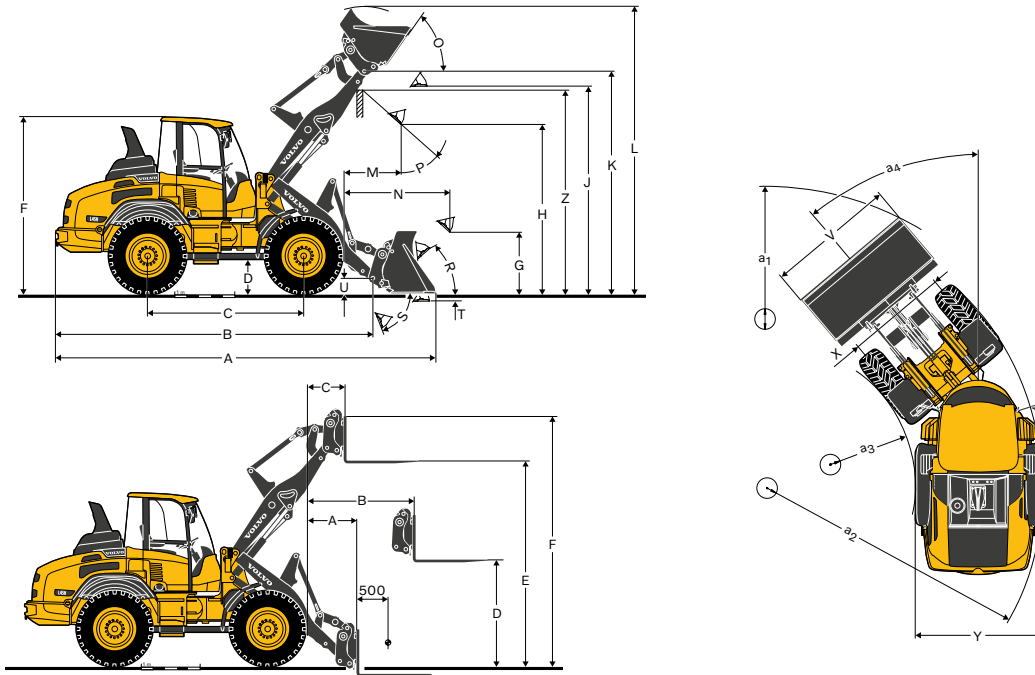

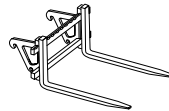
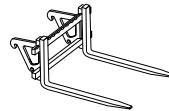

Main flow	l/min (gal/min)	132 (34.8)
Working pressure max	MPa (psi)	26 (3,771)
at engine speed	r/min (r/s)	2 200 (36.6)
Flow auxiliary hydraulics	l/min (gal/min)	120 (31.7)
Working pressure max	MPa (psi)	20 (2,900)
at engine speed	r/min (r/s)	2 200 (36.6)
High flow	l/min (gal/min)	125 (33)
Working pressure max	MPa (psi)	20 (2,900)
at engine speed	r/min (r/s)	2 200 (36.6)









Specifications



		With TP-linkage, TPV attachment bracket and 15.5-25 tires		With TP-linkage, TPZ attachment bracket and 15.5-25 tires	
B	mm in	5 320	209.4	5 325	209.6
C	mm in	2 650	104.3	2 650	104.3
D	mm in	395	15.5	395	15.5
F	mm in	2 950	116.1	2 950	116.1
G	mm in	1 000	39.4	1 000	39.4
J	mm in	3 430	135	3 430	135
K	mm in	3 685	145	3 685	145
O	°		55		55
P	°		45		45
R	°		45		45
S	°		75		75
U	mm in	255	10	255	10
X	mm in	1 750	68.9	1 750	68.9
Y	mm in	2 150	84.6	2 150	84.6
Z	mm in	3 445	135.6	3 360	132.3
a ₂	mm in	4 745	186.8	4 745	186.8
a ₃	mm in	2 555	100.6	2 555	100.6
a ₄	°		40		40

With Loading Fork		TPV attachment bracket		TPV Attachment bracket Long Boom		TPZ attachment bracket		TPZ Attachment bracket Long Boom			
Center of gravity 500 mm / 19.7 in											
A	mm in	785	30.9	1 135	44.7	650	25.6	1 020	40.1		
B	mm in	1 475	58	1 745	68.7	1 375	54.1	1 645	64.7		
C	mm in	650	25.6	825	32.5	550	21.6	725	28.5		
D	mm in	1 705	67.1	1 705	67.1	1 740	68.5	1 740	68.5		
E	mm in	3 490	137.4	3 695	145.5	3 530	139	3 735	147		
F	mm in	4 225	166.3	4 430	174.4	4 265	167.9	4 470	176		
Tipping load full turn (ISO 14397)		kg	lb	4 420	9,744	3 920	8,642	4 670	10,295	4 170	9,193
Working load acc. to EN 474-3, 60/80 %		kg	lb	2 650 / 3 530	5,842 / 7,782	2 350 / 3 130	5,180 / 6,900	2 800 / 3 730	6,173 / 8,223	2 500 / 3 330	5,511 / 7,341
Working load 80%, transport position, 40 deg. and full turn		kg	lb	4 000	8,818	-	-	4 000	8,818	-	-

With TP-Linkage, TPV attachment bracket and 15.5-25 tires			GENERAL PURPOSE				LIGHT MATERIAL				4-in-1		High-Tip		LONG BOOM	
															-	-
Capacity heaped	m ³	yd ³	1.4	1.8	1.5	2.0	1.8	2.4	2.0	2.6	1.2	1.6	2	2.6	-	-
Material density	kg/m ³	lb/yd ³	1 800	3,034	1 700	2,865	1 400	2,360	1 200	2,022	1 900	3,202	1 000	1,685	-300	-505
Static tipping load. straight (ISO 14397)	kg	lb	5 940	13,095	5 860	12,919	5 710	12,588	5 600	12,345	5 580	12,301	4 880	10,758	-	-
Static tipping load. full turn 40° (ISO 14397)	kg	lb	5 250	11,574	5 190	11,442	5 050	11,133	4 960	10,935	4 940	10,890	4 320	9,524	-640	-1,410
Hydraulic lifting capacity. max.	kN	lbf	70	15,736	69.4	15,601	67.5	15,174	66	14,837	66.5	14,950	57.5	12,927	-	-
Breakout force	kN	lbf	71	15,961	69.4	15,601	61.6	13,848	55.8	12,544	76.7	17,242	-	-	-	-
A Total length	mm	in	6 370	250.8	6 385	251.3	6 505	256.1	6 615	260.4	6 295	247.8	6 955	273.8	-	-
L Lift height. max.	mm	in	4 740	186.6	4 790	188.5	4 810	189.3	4 940	194.5	4 815	189.5	5 695	224.2	200	8
V Bucket width	mm	in	2 250	88.6	2 250	88.6	2 250	88.6	2 250	88.6	2 250	88.6	2 250	88.6	-	-
a ₁ Clearance circle	mm	in	10 310	405.9	10 320	406.3	10 390	409	10 460	411.8	10 305	405.7	10 675	420.2	-	-
T Digging depth	mm	in	85	3.3	85	3.3	85	3.3	85	3.3	120	4.7	95	3.7	-	-
H Dump height. 45°	mm	in	2 800	110.2	2 780	109.4	2 690	105.9	2 610	102.7	2 790	109.8	4 230	166.5	200	8
M Reach at max. height	mm	in	940	37	960	37.8	1 040	40.9	1 115	43.9	830	32.6	1 500	59	170	7
N Reach. max.	mm	in	1 770	69.6	1 785	70.2	1 860	73.2	1 935	76.1	1 650	64.9	2 685	105.7	270	10.6
Operating weight	kg	lb	8 770	19,334	8 790	19,378	8 800	19,400	8 830	19,466	8 990	19,819	9 230	20,348	-	-

With TP-Linkage, TPZ attachment bracket and 15.5-25 tires			GENERAL PURPOSE				LIGHT MATERIAL				4-in-1		High-Tip		LONG BOOM	
															-	-
Capacity heaped	m ³	yd ³	1.4	1.8	1.6	2.1	1.8	2.4	2.0	2.6	1,3	1.7	2	2.6	-	-
Material density	kg/m ³	lb/yd ³	1 900	3,202	1 600	2,696	1 400	2,360	1 300	2,191	1 900	3,202	1 100	1,854	-300	-505
Static tipping load. straight (ISO 14397)	kg	lb	6 220	13,712	6 120	13,492	6 020	13,271	5 890	12,985	6 050	13,338	5 260	11,596	-	-
Static tipping load. full turn 40° (ISO 14397)	kg	lb	5 500	12,125	5 420	11,949	5 330	11,750	5 210	11,486	5 350	11,794	4 650	10,251	-640	-1,410
Hydraulic lifting capacity. max.	kN	lbf	74	16,636	72.5	16,298	71.3	16,029	69.5	15,624	72	16,186	62	13,938	-	-
Breakout force	kN	lbf	66	14,837	60.5	13,601	55.5	12,477	50	11,240	65	14,612	-	-	-	-
A Total length	mm	in	6 260	246.5	6 335	249.4	6 415	252.5	6 525	256.9	6 270	246.8	6 825	268.7	-	-
L Lift height. max.	mm	in	4 680	184.2	4 750	187	4 820	189.7	4 890	192.5	4 730	186.2	5 610	220.8	200	8
V Bucket width	mm	in	2 250	88.5	2 250	88.5	2 250	88.5	2 250	88.5	2 250	88.5	2 250	88.5	-	-
a ₁ Clearance circle	mm	in	10 125	398.6	10 165	400.1	10 210	402	10 275	404.5	10 165	400.2	10 590	416.9	-	-
T Digging depth	mm	in	90	3.5	90	3.5	90	3.5	90	3.5	45	1.8	80	3.1	-	-
H Dump height. 45°	mm	in	2 875	113.1	2 815	110.8	2 755	108.4	2 675	105.3	2 865	112.8	4 140	163	200	8
M Reach at max. height	mm	in	860	33.8	900	35.4	955	37.6	1 030	40.5	850	33.4	1 370	53.9	170	7
N Reach. max.	mm	in	1 685	66.3	1 725	67.9	1 780	70	1 855	73	1 670	65.7	2 540	100	240	9.4
Operating weight	kg	lb	8 670	19,114	8 710	19,202	8 700	19,180	8 730	19,246	8 920	19,665	9 120	20,106	-	-



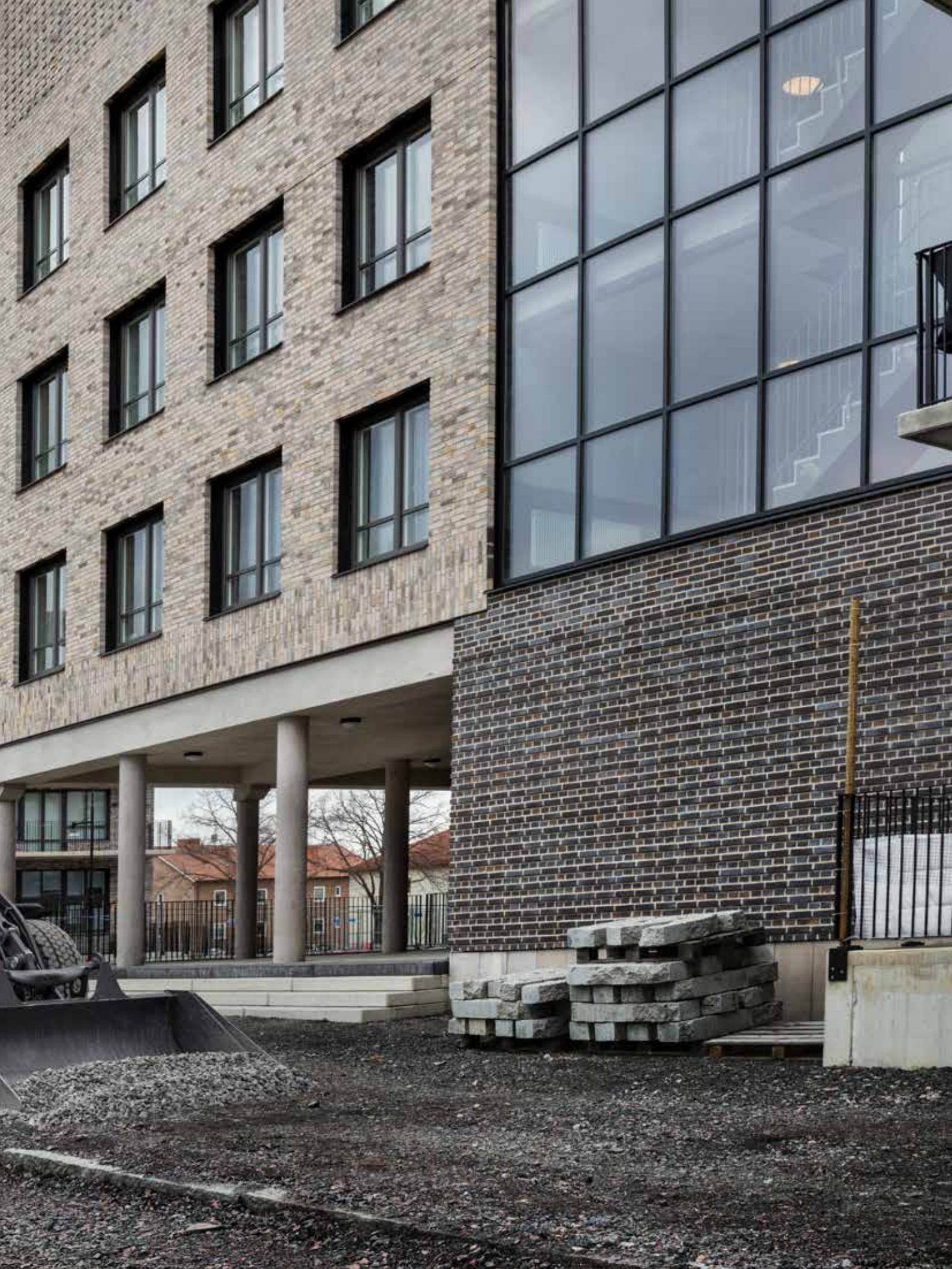

Equipment

STANDARD EQUIPMENT

Engine

Dry-type air filter
Three stage air cleaner, pre-cleaner, primary and secondary filter
Preparation for pre-cleaner
Preheating of induction air
Side by side (single layer) cooling pack
Coolant level monitoring
Filtration screens on air inlets
Fuel pre-filter with water trap
Crank case breather oil trap
Exhaust after-treatment system
Exhaust heat ventilation

Drivetrain

Hydrostatic drive
Inching-brake pedal (hydrostatic wearless braking ahead of service brake application)
Wet disc service brakes, hydraulically operated
Dry disc parking brake
Operator-selected 100% differential locks in both axles

Electrical System

24 V electrical system (2 X 12V maintenance free batteries)
Batteries covered by lockable engine hood
Electronic battery cut-off switch
Alternator 110 A / 3 080 W
Electric horn
Care Track GSM

Hydraulic system

Load-Sensing Hydraulics
Flow sharing main control valve, three-spool system
Variable displacement axial piston pump for working hydraulic and steering
Gear pump for brake system and cooling fan
3rd hydraulic circuit
Bucket positioner
Indicator glass for hydraulic oil level
Thermostatically controlled oil flow to oil cooler (fast warm-up, optimized cooling)

Lights

Main head lights (halogen) upper/dipped/asymmetrical
Working lights, halogen (2 front/2 rear)
Parking lights
Rear lights
Brake lights
Direction indicators
Hazard warning lights
Reversing lights
Cab lighting

Service

Standard tool kit
Drain valves for engine oil, hydraulic oil and coolant
Hydraulic pressure test ports with quick-connects

Instrumentation & controls

24 Volt accessories socket
Hazard warning switch
Safety start

Electronic Information System

Contronic display with keypad
Monitoring of fuel level, fuel consumption, Diesel Exhaust Fluid level, temperatures and pressures (engine, ambient, transmission, hydraulics, brakes and steering)
LED-illuminated symbols are available for direction indicators, transportation & work lights, rotating beacon*, parking brake, engine oil pressure, battery charging, differential lock, boom suspension system*, DEF warning, regeneration and high exhaust temperature. *optional

STANDARD EQUIPMENT

Cab, Exterior

ROPS/FOPS-cab
Cab cushioning
Single key kit door / start
Lockable door
Door stops
All-round tinted safety glass
Sliding window RHS
Two-stage air inlet filtration with large easy to replace elements
External rear view mirrors (right/left)
Windscreen wiper (front/rear)
Windscreen washer (front/rear)

Cab, Interior

Acoustic inner lining
Floor mat
Adjustable steering column
Left and right armrests
4-way adjustable operator's seat
Retractable seat belt
Sunvisor
Interior rear view mirrors
Air conditioner
Automatic heat control
Several air vents on the front and rear of the cab, allowing excellent climate control, demisting and defrosting
Interior light
Coat hook
Cup holder
Storage box in the cab
24 V power outlet
Emergency hammer
Seat mec/susp

Working Equipment

Automatic bucket positioner
Hydraulic quick-change attachment bracket

External equipment

Fenders (front/rear)
Lockable engine hood
Lockable fuel-tank cap
Lockable Diesel Exhaust Fluid filler cap
Vertical exhaust
Frame, joint lock
Towing device
Lifting eyes and Tie-down points

Official approval

Machine conforming to European directive 2006/42/EC
Electromagnetic compatibility (EMC) conforming to European directive 2014/30/EC
Noise emissions in the environment conforming to directive 2000/14/EC
Tipping load and payload conforming to ISO 14397-1
ROPS conforming to ISO 3471
FOPS conforming to ISO 3449

OPTIONAL EQUIPMENT
Engine
Fuel preheater
Handthrottle
Automatic engine shutdown
Turbo II Prefilter
Air pre-cleaner, oil-bath type
Fan speed, high ambient
Reversible cooling fan
Engine Block heater, 120 V
Drivetrain
Hand-inching
20 km/h / 12 mi/h version
30 km/h / 19 mi/h version
40/50 km/h (25/31 mi/h)*
*max vehicle speed market dependent
Electric
Rotating beacon foldable
Preparation for magnetic rotating beacon
Magnetic rotating beacon
Reverse alarm audible
Reverse alarm audible & switchable
Reverse alarm audio visual switchable
Rear view camera incl monitor (color)
LED Working lights on cab, 2 front / 2 rear
LED Working lights on cab, 4 front / 4 rear
Additional LED Working lights, 2 front / 1 rear
Elevated headlights 350 mm / 13.8 in
Road light equipm. width 2.5 m / 8.2 ft
Power outlet 12 V
Anti theft device
Care Track Satellite
Hydraulic equipment
Hyd oil mineral VG46 HV
Hyd oil mineral VG32 HV
Hyd oil mineral VG68 HV
Boom suspension system
Boom kickout
Safety valve for lift cylinder
Combination Boom suspension system with safety valves for boom cylinder
Tilt control
Tilt speed limiter mechanical
Safety valve for tilt cylind.
4th function
Hydr. Couplings
High flow L45H: 125 l/min (33.0 gal/min)
Auxiliary hydraulic's return line (via filter)

OPTIONAL EQUIPMENT
Cab
Door all glass
Door with sliding window
Foldable right hand window
Split door (Door with foldable window)
Heated rearview mirrors
Seat fab air/susp heat
Seat belt 3"
Seat belt warning
Comfort drive control (CDC)
Radio preparation 12 V
Radio
Joystick control including F/R/N, up/down-shift, differential lock and 3rd hydraulic function
Multilever control, including F/R/N, up/down-shift, differential lock, horn and 3rd hydraulic function
Multilever control, including F/R/N, up/down-shift, differential lock, horn, 3rd & 4th hydraulic function
Timer cab heating (Pause heating)
Auxiliary cab & engine heater
Service
Wheel chock
Tool Kit
Central Lub unit (Volvo)
Wheel/Tires
500/70R24
540/65R24
15.5R25
17.5R25
3-piece rim
550/65R25
600/55-26.5
Protective equipment
Front Mudflaps
Extended mudflaps
Mudguard extension 75 mm / 2.95 in
Belly guards, front/rear
Rear lights protection
Headlights protection
Working lights guards, front/rear
Windshield guard, rear
Windshield guard, front
Engine hood protection
Other
Long boom
Preparation for licence plate
Side marking reflectors
SMV warning triangle
Trailer socket
Multiline license plate retainer
Colour Level 1 (yellow parts)
Colour Level 1+2
Attachments / Buckets
Log grapples
Forks
Material handling arm
General Purpose bucket
High-Tip bucket
Light material bucket
Clamp bucket

Not all products are available in all markets. Under our policy of continuous improvement, we reserve the right to change specifications and design without prior notice. The illustrations do not necessarily show the standard version of the machine.

V O L V O