

VOLVO COMPACT EXCAVATOR

EC60C



MORE CARE. BUILT IN.



TO PUSH THE LIMITS YOU MUST KNOW THEM. INSIDE OUT.

When you are looking for solutions to extreme demands on people and machinery at work, you can rely on Volvo, the makers of the world's most popular compact excavators. With its redesigned cabin, the Volvo EC60C matches greater power and performance with class leading comfort. It is an unbeatable combination.

Ready for anything

The new EC60C features one of the highest break-out and tear-out forces in its class. Thanks to its advanced boom and attachment geometry, this power-packed compact lets you stretch further, dig deeper and reach higher. Volvo has developed proven technology by shortening the bucket and tipper dippers to gain greater ripping power, with the articulated boom extending its reach in every direction. As a result, the compact EC60C will size up to any task from picking and sorting to top loading the very largest dump trucks, effectively and fast.

Getting to grips with the job

Volvo has harnessed the high performance of the EC60C to give enormous traction power on site. It will get there faster too, thanks to a 10% increase in travel speed. When excavating, the bucket swivels to bite hard and square. Fully loaded, even at maximum height, it stays tight closed to firmly hold material in. So whatever the job in hand, you have all the power and performance that it takes to tackle any terrain, including rutted ground or slopes.

Saving time on site

Sheer power and smooth hydraulics deliver exceptional performance with no compromise on safety. The simultaneous control of slew and offset movements through a more intuitive interface extends the scope for faster, safer performance, even in confined spaces and slopes. Rotating the hydraulic angle blade saves more valuable time by eliminating the need for repetitive repositioning on site. And because the blade is now positioned further forward, the articulated boom can reach it more easily, enabling the bucket and blade to work more precisely together.

Win both ways

Whether you are looking for great all-round performance or just exceptional choice, the EC60C gives you the best of both worlds. Volvo's new pin-on attachment bracket enables accessories such as the bucket or Volvo thumb for picking and sorting to be switched fast. Thanks to the identical end-of-dipper interfaces on ECRs and conventional Volvo excavators of the same weight, the entire range of Volvo standard buckets, grippers, sorters and rotators are easily interchangeable. So now you are even more certain to find the right tool for the job.



- Massive tractive force to get the job done.



- Bucket and blade work closer together.



- Versatile Volvo thumb can pick or sort.



- Hydraulic angle blade rotates to save time.



- Up to 10% faster travel.
- New pin-on attachment bracket.
- Sheer power for break-out and tear-out.



VOLVO DESIGNERS KNOW YOUR PLACE. THE DRIVING SEAT.

At Volvo, we know how stressful long working hours can be. So we have redesigned the cab of the EC60C compact excavator around you, the operator. Brilliant ergonomics, low noise and high comfort are combined to give you the best operating environment.

Power-assisted precision

Given its prodigious power, the EC60C is surprisingly easy to handle. Movements of the accessory and boom can be simultaneously controlled by the twin joysticks. For fluid, fingertip control the double-acting hydraulic accessory circuit is controlled by a single roller on the right hand joystick. Full electro-proportional control allows the direction and amount of oil flowing to the accessory to be precisely controlled, even when combining operations such as slew and offset.

Smarter to work with

Settle into one of the most spacious cabs in its category and you'll see the benefits right away. Wrap-around glazing give an excellent view out on every side, front and rear. Easily legible gauges on the new electronic instrument panel put essential information about the machine on immediate view. In case of potential overloads, overheating, oil pressure changes or routine service needs, warning lights flash up and audible signals reinforce the message.

From start to finish

For greater power and safety, the EC60C automatically shifts from high to low speed when working on slopes, levelling or backfilling. The intuitive control of slew and offset through precise, natural movements of the joysticks yields well-finished, accurate results faster. Pushing the blade lever forward engages the blade cylinder, exerting minimal, yet consistent downward force for levelling, backfilling, grading or contouring.

More leg space to stretch in

For easy driving and frequent, intensive use, Volvo's EC60C is equipped with heavy-duty travel pedals like those used on heavy excavators. But by mounting the electro-proportional control on the joystick rather than using a foot pedal Volvo's made sure there is plenty of room for even a long-legged operator to work in uncramped conditions on the large, uncluttered floor.

In all weather conditions

As well as built-in heating and demisters, the cab features high-performance air conditioning to combat operator discomfort and fatigue. Whatever the weather, the cab of the EC60C keeps the operator comfortable all day long.

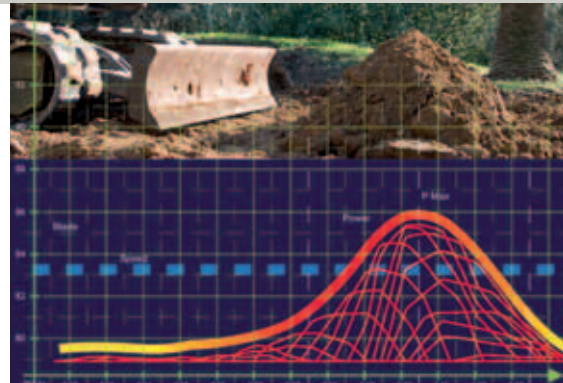

- Automatic two-speed travel.

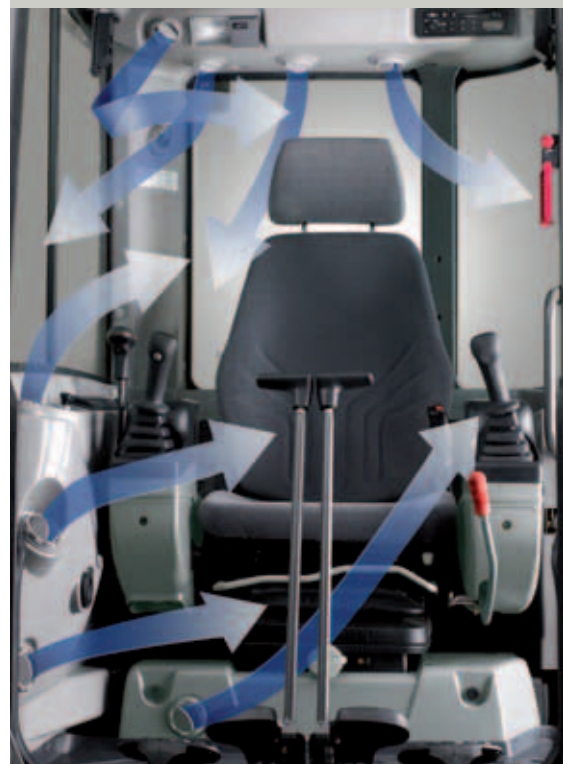

- High performance air conditioning throughout.



- Easy-to-see electronic instrument panel.



- Easy grip joysticks with proportional control. Slew and offset are efficiently combined.



- More room. Greater comfort.
- Float blade enables faster finishing.

QUALITY YOU KNOW YOU CAN RELY ON.

Volvo EC60C excavators are built to offer the very best return on your investment. Endurance testing in the toughest environments has been used to ensure reliability is built into every machine. High performance and dependability come as standard.

Together in harmony

As all quality at work is ultimately in the hands of the operator, we've created the Harmony system to articulate and pilot every move they make. Irrespective of the load and sequence of actions, the speed of each hydraulic movement entirely depends on the operator's touch, almost as if the boom and accessory were extensions of his own arms.

Engineered to last

For smoother operation, precision and productivity, Volvo chose the best power-assisted technology available. Each of the boom, dipper arm and offset cylinders are fitted with devices to slow the cylinder rod before the piston hits the end of its stroke. Cushioning against shocks and jolts this way not only prolongs the machine's working life, but also makes it easier to manage on-site.

New-generation engine

The EC60C features Volvo's latest generation engine technology. Engineered for top performance and diesel economy, it generates fewer emissions and less noise while delivering all the power it takes to guarantee the EC60C carries on working effectively for you throughout its long and productive life.

Quality design

Quality design gives the EC60C features you would normally expect to find in a heavier machine. The X-shaped undercarriage distributes the load to the side members. This gives greater rigidity and strength without extra weight and reinforcement. The result? Better balanced performance. Both upper and lower windows can be slid fully open and secured safely away beneath the roof without dismantling the lower frame assembly.

Guaranteed reliability

To keep the EC60C's electrical circuits dry from mud splashes, the heaviest downpour and even when it's being hosed down, they are fitted with waterproof connections throughout. Similarly, Volvo's patent ORFS (O Ring Face Seal) technology ensures the hydraulic connection joints are 100% leak-free and can be relied on to stay that way - despite pressure peaks, vibration and twisting. Because when it comes to effective maintenance, prevention is always better than cure.



- Power engineering for top performance.



- Volvo smart bucket design.

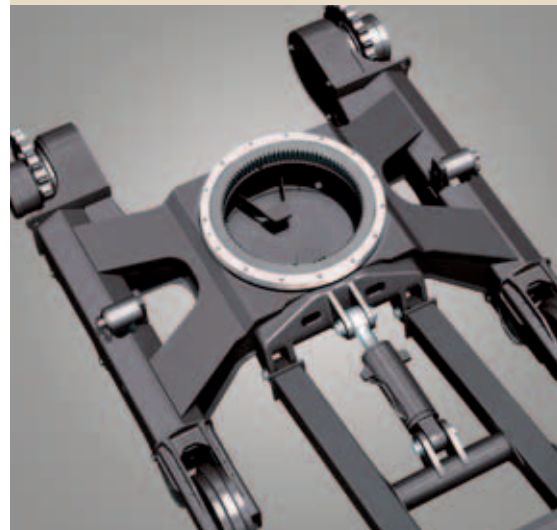

- Structurally reinforced for effective load distribution.



- Windows open fully for extra comfort.
- Quality connectors save on service costs.
- Dipping, tipping and squaring off in perfect harmony.



SAFETY KNOW-HOW.

When you are responsible for operating valuable equipment in difficult, sometimes dangerous conditions on site, there's no room for error. At Volvo, operator safety has always been a top priority, but we also build in benefits for the entire working environment.

Safety at work

The seat belt fits snugly and retracts safely out of harms way when not in use to secure the operator. With Volvo, safety always comes as standard. When not in use, it retracts to protect the belt and buckle. The Volvo EC60C also exceeds the usual standards for this class of machine by providing all-round cab and canopy protection. Falling object, roll-over and tip-over protection to FOPS 1, ROPS and TOPS requirements are all part of the standard Volvo safety package.

See more. Hear more

All four sides of the contoured EC60C cab are fully glazed. A slim, single rear pillar ensures the view to the rear of the excavator is uninterrupted. Placing the machine or working in a confined area is easier and safer. In-cab noise levels are lower than the required European standard, rubber cab mounts reducing noise, heat and vibration reaching the operator. Advanced insulation materials further protect the operator from noise and heat. The result is a safe, quiet and comfortable working environment.

Reduced emissions

It is not just the operator that benefits from the smooth and quiet operation of the EC60C. In enclosed sites and urban areas, the EC60C can work with the minimum of disturbance. The direct-injection Volvo engine meets tough emission standards yet retains the instant response and power operator's demand. This allows the standard Volvo auto-idle system to operate without compromising productivity; after 5 seconds of no control input the engine reverts to idle. Touch a control, and full power is restored. Instantly. The result? Reduced noise, emissions and fuel use.

Security locks

Active locking protects operators getting in or out of the cab. Simply raising the console automatically locks the equipment, offset and travel controls.

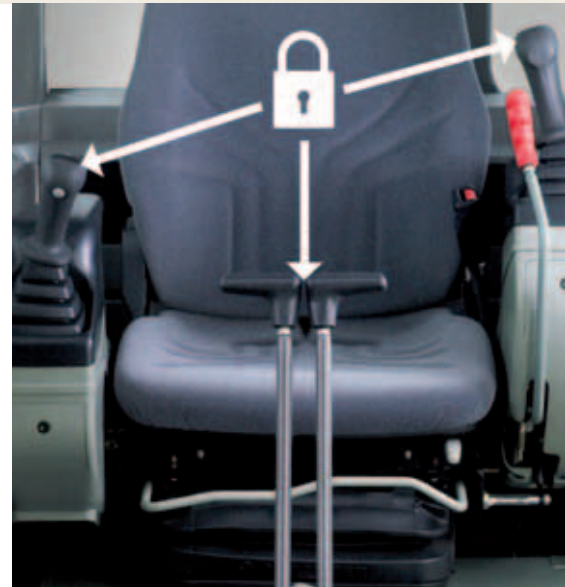

- Active locking prevents accidents.



- Warning when seat belt not engaged.



- All-round visibility for safety at work.



- Quiet operation reduces environmental impact.
- Full protection for the operator.
- Automatic idling cuts noise, emissions and fuel use.



NOW AT YOUR SERVICE.

Volvo construction equipment is made for work and built to last. That's why our global support network is dedicated to help you make the most of every working day.

No time wasted

The high capacity 110 litre fuel tank on the EC60C is fitted with its own integral 35 litre per minute filling pump. This allows the unit to be refuelled quickly from ground level tanks and barrels.

Easier maintenance

Cables, connections and components are readily accessible for routine upkeep and maintenance. Simply open the wide rear cover for total access to all critical check points.

Reduced wear and tear

Sweeping the spacious cabin interior clean is no problem because there's no offset pedal to clutter the floor, and the mat has no ribs for the dust, dirt or gravel to collect in. Likewise the sloping side member prohibits the build-up of earth to save cleaning and maintenance time. All of which makes maintaining the machine, and its market value, a little easier every day.

Genuine accessories

Volvo dealers are on-call for the prompt delivery of genuine Volvo spares and accessories from hydraulic oils to steel track protectors.

Volvo warranty service

For full fleet cover on virtually any site in the world, Volvo's Caretrack System keeps close track of your machines through real time monitoring from the moment they leave our factory.

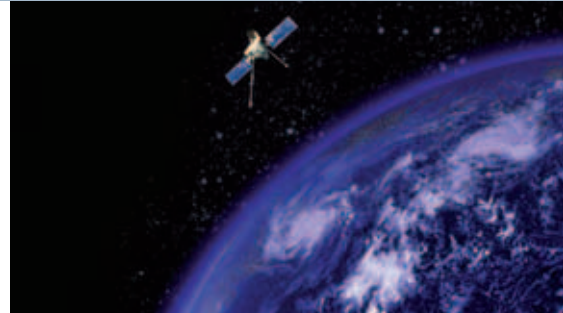

- Volvo advanced care track ensures full fleet cover.



- Dealers on-call worldwide.



- Mobile pump for faster refuelling.



- Sloping side design requires less maintenance.



- Rely on quick Volvo parts availability.
- Fast and easy maintenance .



SPECIFICATIONS

Engine

Water-cooled Volvo 4-cylinder diesel engine. Compliant to EPA Interim Tier 4 / EU Stage IIIA environmental regulations.

Model	D3.1D
Gross power, rated (ISO 9249)	36.2 kW @ 2100 rpm
Power, installed (ISO 9249)	35.1 kW @ 2100 rpm
Displacement, total	3054 cc
Maximum torque	193~210 Nm @ 1400 rpm ± 100 rpm
Bore x stroke	94 mm x 110 mm

Electrical system

Rated voltage	12 V
Battery capacity	12 V - 100 Ah x 1EA
Alternator rating	12 V - 55 Ah
Starter motor output	12 V - 3.0 kW

Hydraulic system

Variable displacement Total Power Control hydraulic system providing total independence of all movements and of travel.

Control	Power-assisted hydraulic controls
----------------	-----------------------------------

Variable displacement double pump for the equipment (boom, dipper and bucket) and travel circuits:

Maximum flow	2 x 57.8 l/min
Maximum operating pressure	21.6 Mpa (216 bar)

Gear pump for the power assistance circuit:

Maximum flow	13.7 l/min
Maximum operating pressure	3.2 Mpa (32 bar)

Double-acting hydraulic circuit for accessories:

Maximum flow	57.8 l/min
Maximum operating pressure	21.6 Mpa (216 bar)

2nd accessory circuit:

Maximum flow	19.6 l/min
Maximum operating pressure	21.6 pa (216 bar)

End-of-stroke cushion:

On boom ram	at the end of the rod extension
On dipper ram	on both sides
On offset ram	on both sides
Offset ram lock	on both sides

The equipment's offset ram is equipped with a balancing valve which holds the boom offset angle in the position chosen by the operator in all working conditions.

Slewing system

Turntable slewing is provided by a radial piston hydraulic motor which drives directly (without a reduction gear) a ball internal crown wheel with remote lubrication.

Slewing speed	8.8 rpm
Turntable braking	automatic multi-disc brake
Absorption of hydraulic shocks	Shockless valve

Bucket performance

Breakout force	4138 daN
Tearout force	2844 daN

Undercarriage

The undercarriage is made up of an "X" box fabricated centre part for more rigidity and of sloping side members for a better clearance of materials. The rollers and the tensioning wheels are lubricated for life.

Bottom/top rollers per side	5/1
Track width	400 mm
Track tension	by grease piston
Blade (width x height)	1920 x 350 mm

Travel system

Each track is driven by an axial piston hydraulic motor equipped with two gears and an epicyclic reduction gear. Braking is provided automatically by a multiple disc brake.

Travel speed (low / high)	2.4 / 4.5 km/h
Max. tractive force	4413 daN

The forward movement control is automatically locked when the operator raises the left console.

Service fill capacities

Fuel tank	110 l
Hydraulic system, total	134 l
Hydraulic tank	84 l
Engine oil	11.5 l
Cooling system	16 l

Weight

Operational weight and ground pressure:

Rubber Tracks (400 mm)	5700 kg - 0.36 kg/cm ³
Steel Tracks (380 mm)	5790 kg - 0.39 kg/cm ³

Noise level

The EC60C conforms to the 2006 European Machine Directive Noise Level (2000/14/CE) of 97 dB(A) for this class of machine.

Noise level exterior (LwA)	< 97 dB(A)
Noise level in the cab (LpA)	< 78 dB(A)

The noise levels conform to directive n°4 86/662 EEC and its amendments.

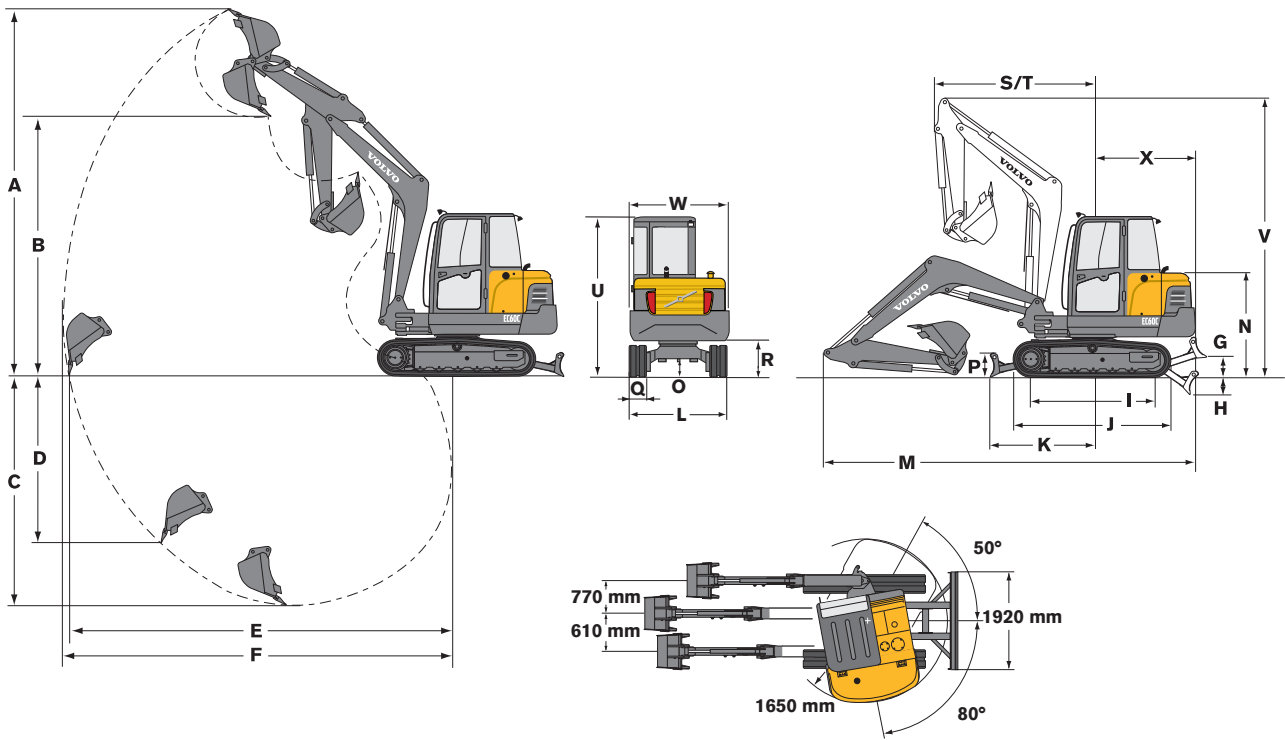

Dipper	A	B	C	D	E	F
1600 mm	5680	4140	3750	2590	5960	6100
1900 mm	5870	4330	4050	2860	6250	6390

* Dig depth with the blade down.

G	H	I	J	K	L	M	N	O
380	508	1950	2500	1747	1920	5872	1628	380

P	Q	R	S	T	U	V	W	X
349	400	690	2480	-	2563	4362	1850	1650

In mm

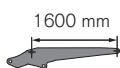

These capacities are given for a machine without a bucket or quick-release coupling and fitted with rubber tracks. The handling capacity is 75% of the tipping load or 87% of the hydraulic limit.

Caution: In accordance with standard EN 474-5, the machine must be fitted with a safety valve on the boom ram and with an overload indicator for handling operations.

Horizontal Range		1 m	2 m	3 m	4 m	5 m	Max
Rubber Tracks 	 Z2	-	-	-	1070	-	760
	Z1	*2430	2660	1380	920	690	650
	Z3	*4090	2710	1410	-	-	960
	Z2	-	-	-	1080	740	680
	Z1	*2060	2600	1360	900	670	590
	Z3	*3380	*2320	*1360	-	-	820

* hydraulic limit

In kg

  Lifting capacity in total rotation over 360°/4 with the blade raised.

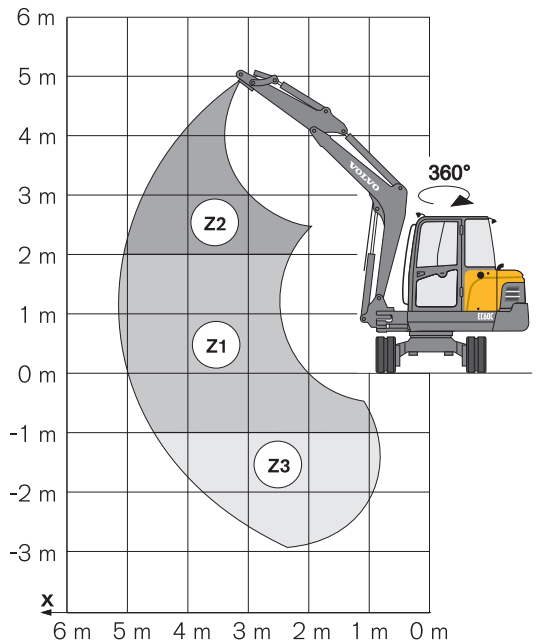

STANDARD EQUIPMENT

Engine

Low-emission Volvo engine meeting EPA Interim Tier 4 / EU Stage IIIA environmental regulations.
Two-stage air filter with blinding indicators.
Electric heating device.
Diesel filter and sediment chamber.
Electric fuel tank filling pump (35 l/min).
Automatic return to idling.
Telene engine hood.
Oil sump sheet metal.
Smooth sound dual case muffler.

Electrical system

Maintenance-free 12 V - 100 AH battery.
Starter motor 12 V - 2.3 kW.
Halogen working lights (2 on the turret and 1 on the boom).
Water-resistant electrical connectors (IP67).
Horn.

Undercarriage

(400 mm) width rubber tracks.
Float blade.
Remote lubrication of the slew ring.

Hydraulic system

ISO power-assisted hydraulic control.
Cylinder cushions with contamination seals.
Total Power Control system.
Boom anti-lowering device.
Multiple filtration system (30 µm).
Double-acting hydraulic circuit for accessories fitted on the boom.
Accessory circuit and the boom offset are controlled by an electroproportional control on the right joystick.
Progressive finger-tip control of the accessory circuit & offset.
Control of forward and backward movement by two levers coupled to pedals.

Cab

Heating and air conditioning.
8 air vents.
Tinted windows.
Non-slip floor and grab handle for access to the driver's cab.
Multi-adjustable, full suspension, high-back, console/seat assembly.
"Deluxe" fabric-covered superior comfort seat (cab).
Hinged front window.
Removable bottom front window.
Sliding right side window.
Rear Mirror in Cabin.
Rubber mounting.
Radio/cassette player with 2 speakers.
Flexible aerial.
Interior lighting.
Heavy-duty travel pedals.
Intermittent windscreen wiper and windscreen washer on the front window.
Power socket.

Instrumentation and monitoring

Monitoring and warning light for the following functions: pre-heating, engine oil pressure, water temperature, battery charge, air filter clogging.
Internal and external fuel gauges.
Hour meter.
Hydraulic flow adjustment of the accessory circuits on the instrument panel.

Handling and earthwork equipment

(3000 mm) long monobloc boom.
(1600 mm) dipper arm.
Remote lubrication of the offset and dipper arm cylinders.

Safety

Device for locking the earthwork equipments controls and the travel levers when the left console is raised to gain access to driver's cab.
Engine starting safety device: the left console must be raised to operate the starter.
FOPS 2 (Falling Objects Protective Structure).
ROPS 2 (Roll-Over Protective Structure)
TOPS (Tilt-Over Protective Structure)
Safety valve on the blade cylinder.
Pressure accumulator on the power assistance circuit in order to be able to put the equipment on the ground if the engine is switched off.
Window-breaker hammer (cab).
Seatbelt with visual indicator system.
Anti-theft system integrated in the instrument panel.

Official approval

Machine conforming to European directive 98/37/EC.
Noise emissions in the environment conforming to directive 2000/14/EC.
Object handling device conforming to EN 474-5 standard.
ROPS conforming to ISO standard 3471/SAE J 1040.
FOPS 2 conforming to ISO 3449:2005 standard.
TOPS conforming to ISO 12117 and EN 13531 standards.
Electromagnetic compatibility (EMC) conforming to European directive 89/336/EC and its amendments.
Hand Arm Vibrations - Whole body Vibrations: compliant with directive 2002/44/EC:
HAV < 0.5 ms² - WBV < 2.5 ms².

OPTIONAL EQUIPMENT

Handling and earthwork equipment

(1900 mm) Dipper arm.
Safety valve piloted by the power assistance circuit on the boom arm cylinder with overload indicator.
Safety valve on the dipper arm cylinder.
Quick-release accessories coupling.
2nd accessory circuit operated by electroproportional control on left joystick.
Heavy-duty dipper arm.

Undercarriage

Steel tracks: 380 mm or 500 mm.
Angle blade.
Wide blade: 2020 mm.

Lighting

Additional front and rear working light.
Rotating beacon.

Environmental protection

Bio-degradable hydraulic oil: 46.

Service and maintenance

Toolkit.

Safety

Care Track.
Retracting seatbelt with visual indicator (2" or 3").
FOPS 2/FOG windscreen guard.
Right and left rear sides view mirrors.

Miscellaneous

Special customised paint (RAL specifications).
Pilot control change valve.
Cold weather hydraulic oil: 32.

ATTACHMENT OFFER

Volvo Hydraulic Breaker HB300
Low Noise with a wide range of additional work tools.

New Volvo pin on Attachment Bracket (VAB)

- Mechanical
- Hydraulic.

Volvo hydraulic Thumb

Complete range of Volvo genuine buckets

- Trenching
- Ditching.



VOLVO

EC60C



Volvo Construction Equipment is different. It's designed, built and supported in a different way. That difference comes from an engineering heritage of over 170 years. A heritage of thinking first about the people who actually use the machines. About how to help them be safer, more comfortable, more productive. About the environment we all share. The result of that thinking is a growing range of machines and a global support network dedicated to helping you do more. People around the world are proud to use Volvo. And we're proud of what makes Volvo different - **More care. Built in.**



Not all products are available in all markets. Under our policy of continuous improvement, we reserve the right to change specifications and design without prior notice. The illustrations do not necessarily show the standard version of the machine.

VOLVO

Volvo Construction Equipment
www.volvo.com

Ref. No. 30 B 100 5012
Printed in Sweden
Volvo, Belley

English
2009.09
CEX